

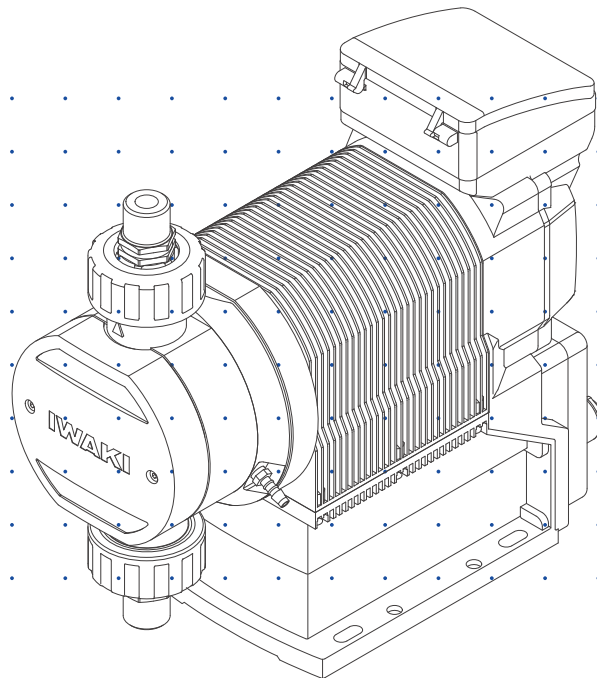

Hi-Techno Pump

IX series



Instruction manual

Thank you for choosing our product.

 Please read through this instruction manual before use.

This instruction manual describes important precautions and instructions for the product. Always keep it on hand for quick reference.

Order confirmation

Open the package and check that the product conforms to your order. Also, check each of the following points. For any problem or inconsistency, contact your distributor at once.

a. Check if the delivery is as per order.

Check the nameplate to see if the information such as model codes, discharge capacity and discharge pressure are as per order.

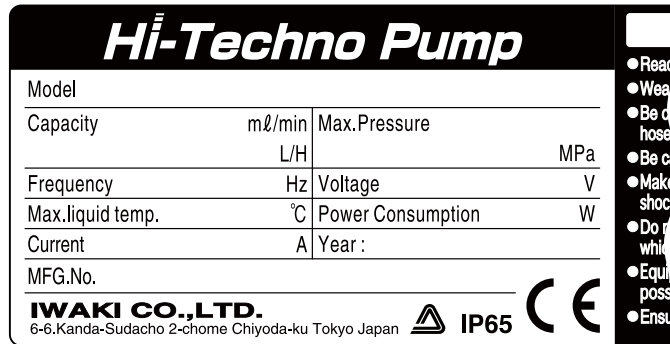

b. Check if the delivery is damaged or deformed.

Check for transit damage and loose bolts.

Contents

Order confirmation	2
<i>Safety instructions.....</i>	6
Warning	7
Caution	8
Precautions for use	10
<i>Outline</i>	12
Introduction	12
Pump structure & Operating principle	12
Features	13
Operational function	13
Manual operation	13
EXT Modes	14
AUX function	16
Priming function	16
STOP function.....	16
Pre-STOP function.....	17
Protective functions.....	18
Output function.....	19
Other functions.....	19
Part names.....	20
Pump.....	20
Operational panel.....	21
Basic displays & Pump states	22
Identification codes	23
Pump.....	23

Installation 24

Pump mounting..... 24

Pipework 25

 Piping layout..... 25

Drain port (Vent hole) 26

Wiring 27

 End terminals 27

 Power supply/Earthing 28

 Signal wire connection 29

 STOP signal 30

 Input signal..... 30

 AUX signal..... 31

 Output signal 31

Operation 32

Before operation 32

 Points to be checked..... 32

 Retightening of pump head fixing bolts 32

 Commissioning..... 33

 Before a long period of stoppage (One month or more) 33

Perform a calibration..... 34

 Calibration process 35

Operation programming..... 37

 Programming flow 38

 Menu screen 39

 EXT mode selection..... 40

 Calibration..... 42

 Signal input setting..... 42

 Alarm 1 setting 44

 Alarm 2 setting 45

 Data logging 46

 Programming of other functions..... 47

Operation 49

 EXT operation 49

 Manual operation 50

 Priming function 50

Maintenance.....51

Troubleshooting 52

Pump 52

Inspection 53

Daily inspection 53

Periodic inspection 53

Wear parts replacement 54

Wear part list 54

Before replacement..... 55

Valve set replacement..... 55

Discharge line 55

Suction line..... 56

Exploded view 60

Pump head, Drive unit & Control unit..... 60

Pump..... 61

IX-C150TCR..... 61

IX-C150TCF 62

Specification/Outer dimension..... 63

Specification..... 63

Pump 63

Control unit..... 64

Power cable 65

Body colour 65

Outer dimension 66

IX-C150TCR-TF 66

IX-C150TCR-RF..... 67

IX-C150TCR-LF 68

Safety instructions

Read through this section before use. This section describes important information for you to prevent personal injury or property damage.

■ Pictorial indication

In this instruction manual, the estimated risk of degree caused by incorrect use is ranked with the following pictorial indications. First, fully understand information on the pictorial indications.



WARNING

Indicates mishandling could lead to a fatal or serious injury accident.



CAUTION

Indicates mishandling could lead to personal or property damage.

Pictorial indication accompanies each precaution, suggesting "Caution", "Prohibition" and "Requirement".

Caution marks



Caution



Electrical shock

Prohibition mark



Prohibition



Do not remodel

Requirement mark



Requirement



Wear protectors



Earthing

⚠ For exportation

Technology related to the use of goods in this instruction manual falls in the category of technology contained in the Foreign Exchange Order Attachment, which includes complementary export control of technology. Please be reminded that export license, which is issued by the Ministry of Economy, Trade, and Industry could be required, when this is exported or provided to someone even in Japan.

⚠ WARNING

Electrical shock

Turn off power before work

Risk of electrical shock. Be sure to turn off power to stop the pump and related devices before work.



Requirement

Stop operation

On sensing any abnormality or dangerous sign, suspend operation immediately and inspect/solve problems.



Prohibition

Do not use the pump in anything other than a specified purpose

The use of the pump in any purpose other than those clearly specified may result in failure or injury. Use this product in a specified condition only.



Do not remodel

Do not modify the pump

Remodelling the pump carries a high degree of risk. We are not responsible for any failure or injury results from remodelling.



Wear protectors

Wear protective clothing

Always wear protective clothing such as an eye protection, chemical resistant gloves, a mask and a work cap during dismantlement, assembly or maintenance work.



Prohibition

Do not damage the power cable

Do not pull or knot the power cable or place a heavy stuff on it. Damage to the power cable could lead to a fire or electrical shock when it is bared or disconnected.



Prohibition

Do not use the pump in a flammable atmosphere

Do not place dangerous or flammable goods near the pump for your safety.

CAUTION



Requirement

A qualified operator only

The pump must be handled or operated by a qualified person with a full understanding of the pump. Any person who is not familiar with this product should not take part in operation or management.



Prohibition

Use a specified power only

Do not apply any power other than the one specified on the nameplate. Otherwise, failure or fire may result. Also, be sure to earth the pump.



Prohibition

Do not wet electric parts or wiring

Risk of fire or electrical shock. Install the pump free from liquid spill.



Caution

Ventilation

Poisoning may result when handling a toxic or odorous liquid. Keep good ventilation in your operating site.



Prohibition

Do not install or store the pump in the following places where...

- Under a flammable atmosphere or in a dusty/humid place.
- Ambient temperature is beyond 0-50 degrees Celsius.
- Under direct sunlight or wind & rain.



Requirement

Countermeasure against efflux

Take a protective measurement against an accidental chemical overflow results from pump or piping breakage.



Prohibition

Do not use the pump in a water place

The pump is not totally waterproof. The use of the pump in water or high humidity could lead to electrical shock or short circuit.



Earthing

Earthing

Risk of electrical shock. Always earth the pump.

Electrical
shock**Install an earth leakage breaker**

An electrical failure of the pump may adversely affect related devices. Purchase and install an earth leakage breaker separately.



Requirement

Wear part replacement

Follow instructions in this manual for wear part replacement. Do not dismantle the pump beyond the extent of the instructions.



Prohibition

Do not use a damaged pump

Using a damaged pump could lead to an electric leak or shock.



Requirement

Disposal of a used pump

Dispose of any used or damaged pump in accordance with relevant regulations. Consult a licensed industrial waste products disposing company.



Caution

Tighten the pump head

Liquid may leak if eight M8 pump head fixing bolts have been loosened. Remove a bolt cover and tighten the bolts diagonally and uniformly by 10 N•m before initial operation or at periodic intervals.

Precautions for use

- Electrical work should be performed by a qualified operator. Otherwise, personal injury or property damage accident may result.



- Do not install the pump in the following places where...
 - Under a flammable atmosphere or in a dusty/humid place.
 - Under direct sunlight or wind & rain.
 - Ambient temperature is beyond 0-50 degrees Celsius.

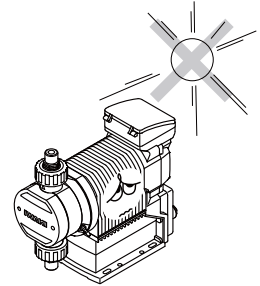

- Select a level location where is free from vibration and liquid can't stay. Anchor the pump with four M8 bolts so as not to vibrate. If the pump is installed at a tilt, the flow may reduce.

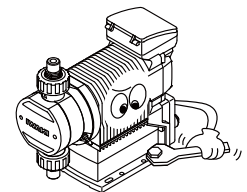

- When two or more pumps are installed, the pumps may start to vibrate significantly, resulting in poor performance or failure of internal electrical devices. Select a concrete foundation and fasten anchor bolts tightly to prevent the pumps from vibrating during operation.



- There should be sufficient space around the pump to enable efficient and easy maintenance.



- Install the pump as close to a supply tank as possible.



- Install the pump in a cool and dark place when handling liquids that readily generate gas bubbles such as sodium hypochlorite or hydrazine solution. Flooded suction application is strongly recommended when mounting the pump below the level of liquid in the supply tank.



- The suction line bore should be wider than the inlet bore of the pump.



- Keep the pump free from any effect of piping expansion and contraction due to thermal stress.



- Overload protection will stop operation when the discharge pressure has risen to 1.5 to 2 times higher than the maximum. Install a relief valve to depressurize a discharge line if the pressure resistance of discharge line will not bear the possible highest pressure.



- Be careful not to drop the pump onto the floor. A strong impact may reduce pump performance. Do not use a pump which has once damaged. Otherwise an electrical leak or shock may result.

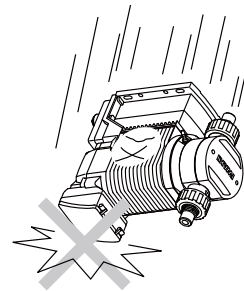

- The pump is water-/dust-proof of IP65, but is not totally waterproof. Do not have the pump wet with the liquid handled or rainwater.



- Never wet the pump head, control unit and drive unit. Otherwise, Failure or an accident may result. Immediately wipe off liquid if the pump has got wet.



- Do not close the discharge line during operation. Otherwise, liquid may leak or piping may break. Install a relief valve to be sure to prevent a leak or a piping break.



- Release the pressure from the discharge line before dismantling the pump or removing piping. Otherwise, chemical liquid gushes out.



- Be careful not to come in contact with residual liquid.



- Do not clean the pump or nameplate with a solvent such as benzene and thinner. This may discolour the pump or erase printing. Use a dry cloth or a wet cloth with water or neutral detergent.



Outline

The information such as characteristics, features and part names are described in this section.

Introduction

Pump structure & Operating principle

The IX series are diaphragm pumps with a BLDC motor and feature a high turndown ratio & automatic controls.

Principle of operation

In the IX series design, a BLDC motor rotation controls a flow rate.

Motor rotation is transmitted to an eccentric cam through a reduction gear and then converted to reciprocating motion. Volumetric change occurs in the pump chamber as a diaphragm moves back and forth and pumps liquid along with valve action. A flow rate changes with a discharge speed. On the other hand, a suction speed is always the same at any flow rate.

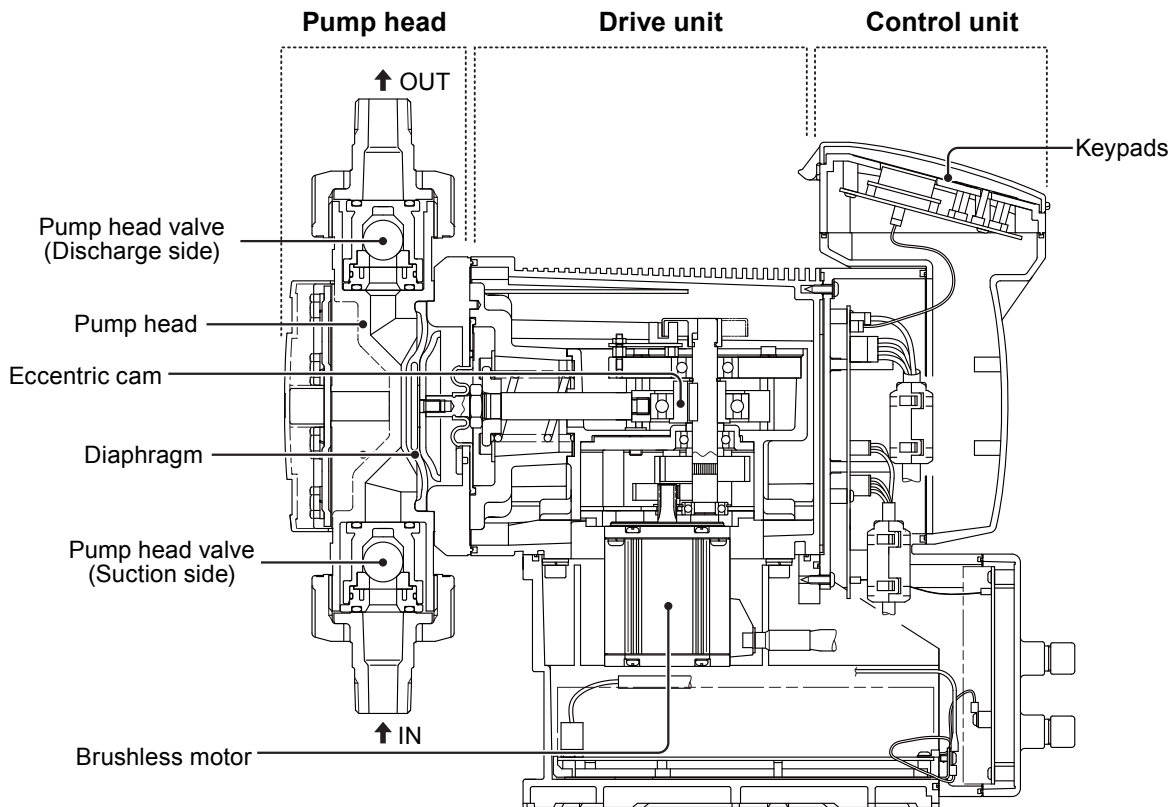

Features

- **High turndown ratio**

Use of a BLDC control motor offers 750:1 turndown ratio.

- **High repeatability**

Highly-efficient valve design and accurate discharge-/suction-speed controls assure the high repeatability of chemical dosing ($\pm 1\%$).

- **Energy-saving design**

Use of helical gears and an assist spring reduces the power consumption by 70% compared to our conventional metering pump designs (spring back).

- **Automatic control**

The IX can automatically run along with analogue-, pulse-, batch- or interval batch-operation programming.

- **Multi voltage operation**

The IX series can be used in all countries thanks to the universal power supply (100-240VAC).

- **Safety design**

A diaphragm rupture detection ensures user safety and an overload detection protects the pump and pipe-work from an accidental discharge line pressure rise.

Operational function

- **Manual operation (See page 50)**

The start/stop of the pump by key operation

The operation LED lights in green colour during operation.

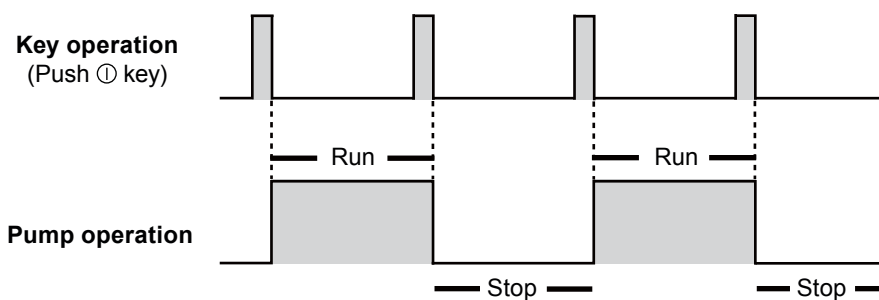

■ EXT modes

Analogue control (See page 40 & 49)

Select a proportional control pattern. 4 - 20mA, 20 - 4mA, 0 - 20mA and 20 - 0mA are available.

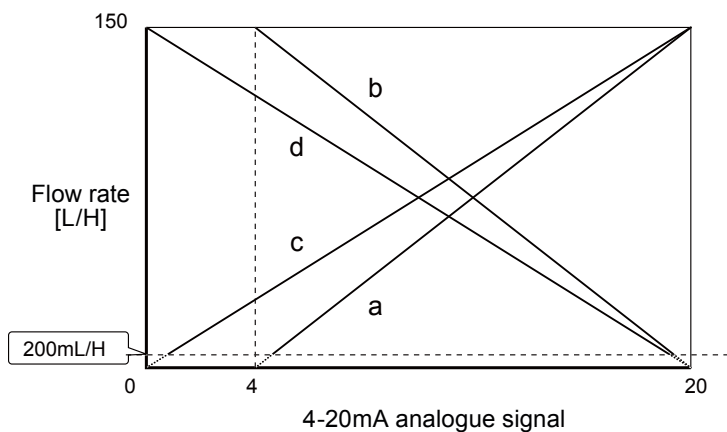

Condition

The left graph is in the following patterns.

- a. 4-20mA (Default setting)
- b. 20-4mA
- c. 0-20mA
- d. 20-0mA

*A flow rate does not fall below 200mL/H at any current value.

Example of use: pH control in water treatment system

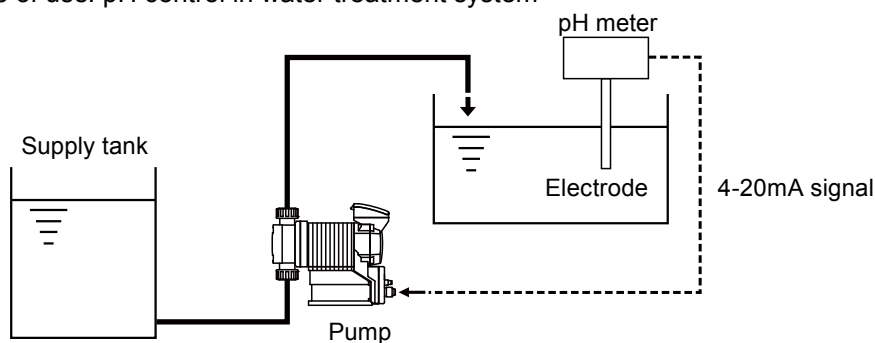

Pulse control (See page 40 & 49)

The frequency of a pulse signal controls a flow rate. A dosing flow per pulse changes in proportion to the frequency.

*It takes about 10 pulses for the IX to catch up with a specified flow rate after the frequency of a pulse signal is changed.

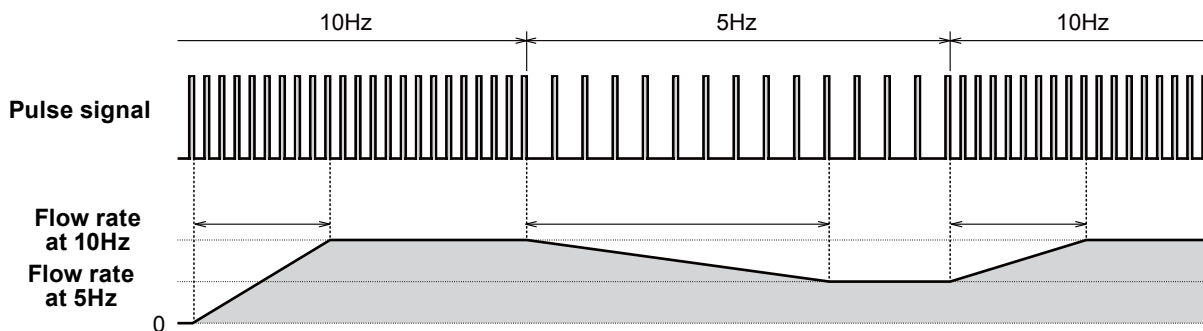

Example of use: Chemical dosing in sewage treatment system

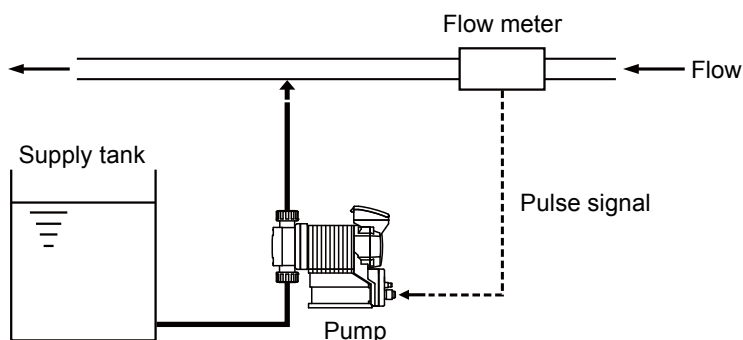

Batch control (See page 40 & 49)

The IX runs for a programmed flow rate as receiving a pulse signal.

When the pump receives pulse signals in dosing, the signals are stored up to 65535 and then sequentially processed.

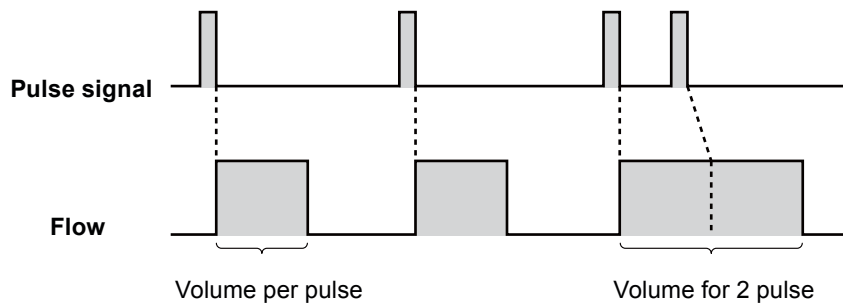

Example of use: Chemical dosing in production line system

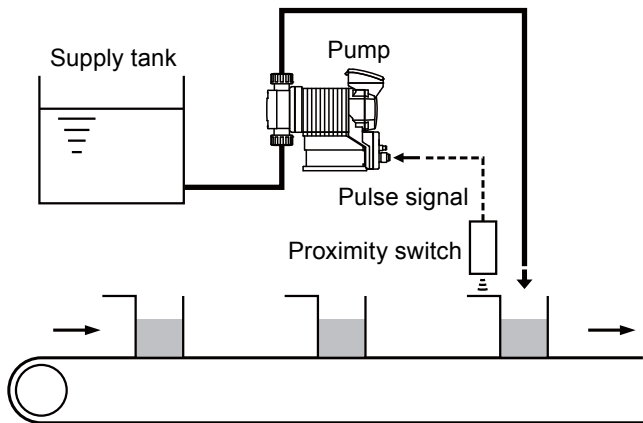

Interval batch control (See page 41 & 49)

To make an interval batch control, set a date and time interval and a flow rate. The pump starts to run as receiving a pulse signal. The operation LED lights greenly during operation and starts to blink when the start/stop key is pushed to stop operation.

In the diagram below, a time interval is set to 1 hour.

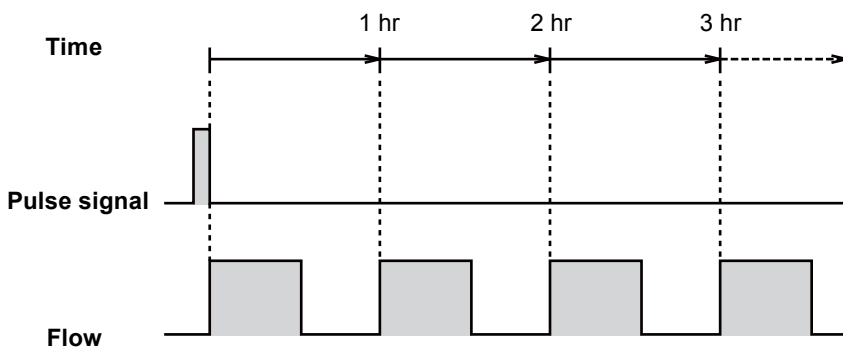

Use of example: Water transfer for sprinkler system

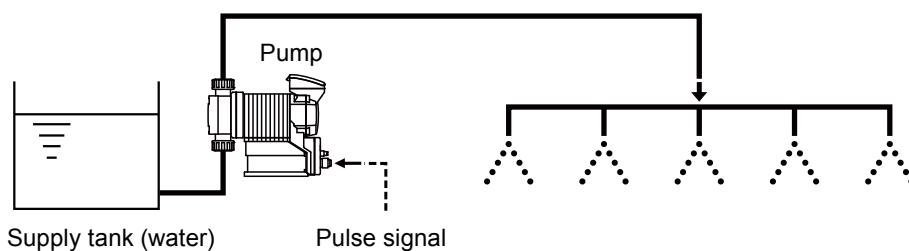

■ AUX function (See page 47)

The pump runs at a set flow rate while receiving the external signal via the AUX terminal. Use this function for degassing or priming.

*This function is available at any time except when the pump is in the MAN/EXT selection or menu selection.

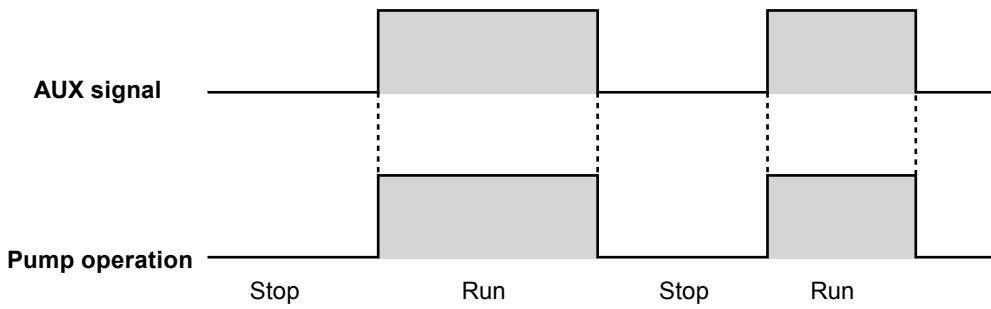

■ Priming function

The pump runs at the maximum stroke rate while both the UP and DOWN keys are pressed. Use this function for degassing.

Press and hold both the keys for 10 seconds and then release the keys to leave the pump running in this state. Push the start/stop key to stop operation.

*This function is available at any time except when the pump is in the MAN/EXT selection or menu selection.

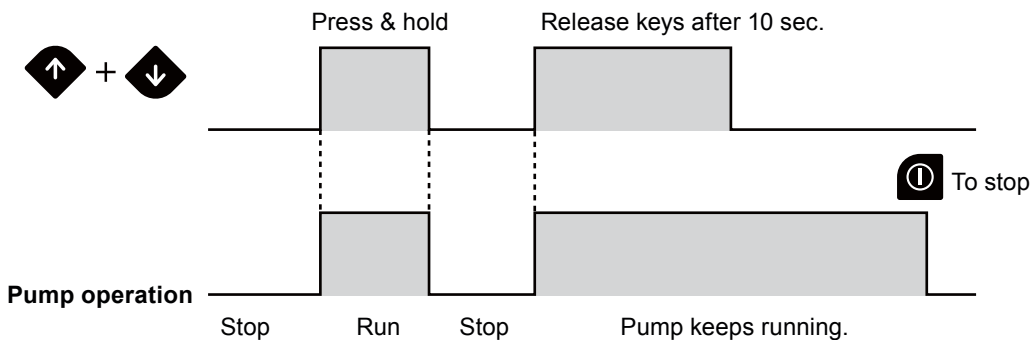

■ STOP function (See page 42)

The start/stop of operation can be controlled by a signal from a level sensor.

See page 30 "STOP signal" for wiring diagram.

When Make-OFF is selected...

The pump stops and the operation LED lights in red colour while receiving the stop signal (closed circuit).

*The pump resumes operation when the stop signal is released.

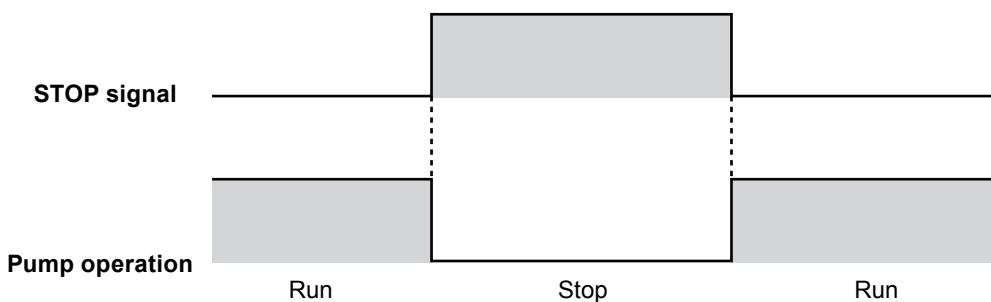

When Make-ON is selected...

The pump runs and the operation LED lights in green colour while receiving the stop signal (closed circuit).

*The pump stops operation when the stop signal is released.

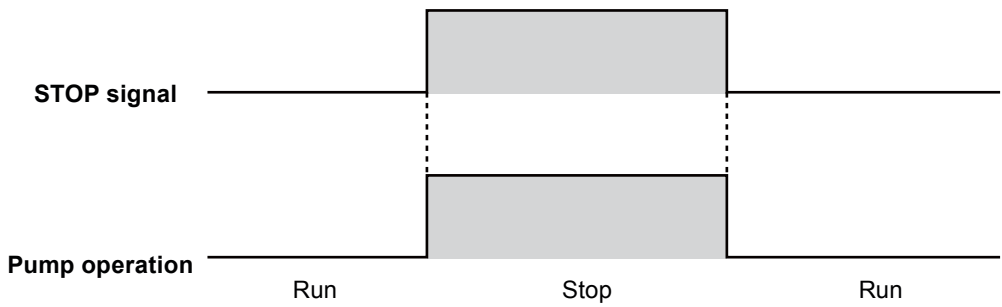

■ Pre-STOP function (See page 42 & 43)

Liquid level in a supply tank can be monitored by a signal from a level sensor. See page 30 for wiring diagram.

When Make-OFF is selected...

The operation LED lights in orange colour while the pump is receiving the Pre-STOP signal (closed circuit).

When Make-ON is selected...

The operation LED lights in orange colour while the pump is not receiving the Pre-STOP signal (open circuit).

Example of use: When setting both Pre-STOP and STOP signals to Make-OFF, the operation LED lights in orange colour to inform a user that liquid comes close to the minimum level in a supply tank and the pump stops when liquid has fallen below the minimum level.

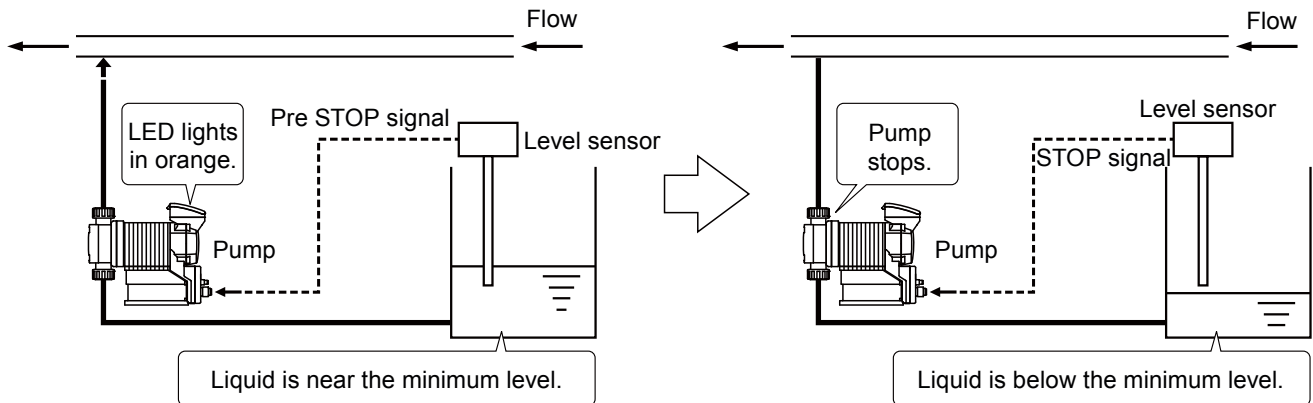

■ Protective functions

Interlock function (See page 42 &43)

The start/stop of operation can be controlled by a signal from an external device.

Interlock function works in the same way as the STOP function but uses a preference circuit. Use this function for emergency stop.

*This function is available at any time except when the pump is in the MAN/EXT selection or menu selection.

Diaphragm rupture detection (See page 42 &43)

The diaphragm rupture detection stops the pump immediately after sensing a leak.

In this state the operation LED lights in red colour.

Replace a broken diaphragm as necessary. See page 58 for diaphragm replacement.

Push the start/stop key after replacing a diaphragm to resume operation.

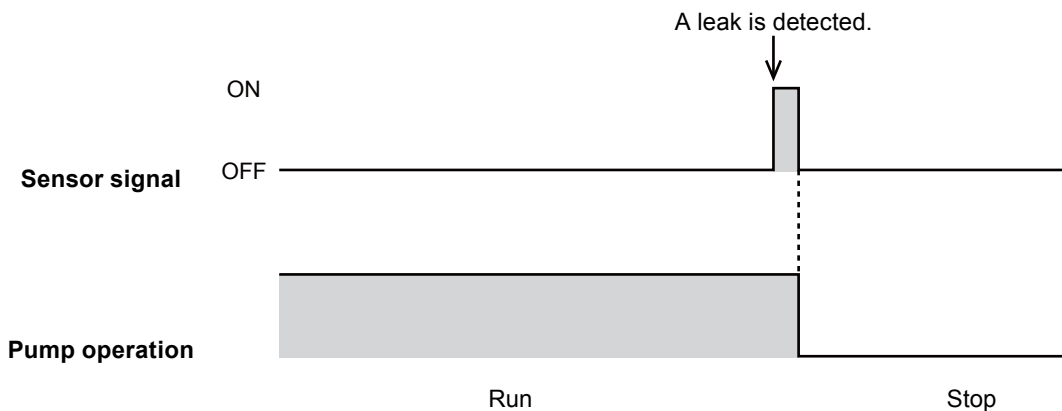

Overload detection

The overload detection stops the pump immediately after sensing overload.

In this state the operation LED lights in red colour.

The pump resumes operation 30 seconds after the stoppage. If overload recurs and the detection works 5 times, the pump will not resume operation any more and keep still.

Push the start/stop key to release this state.

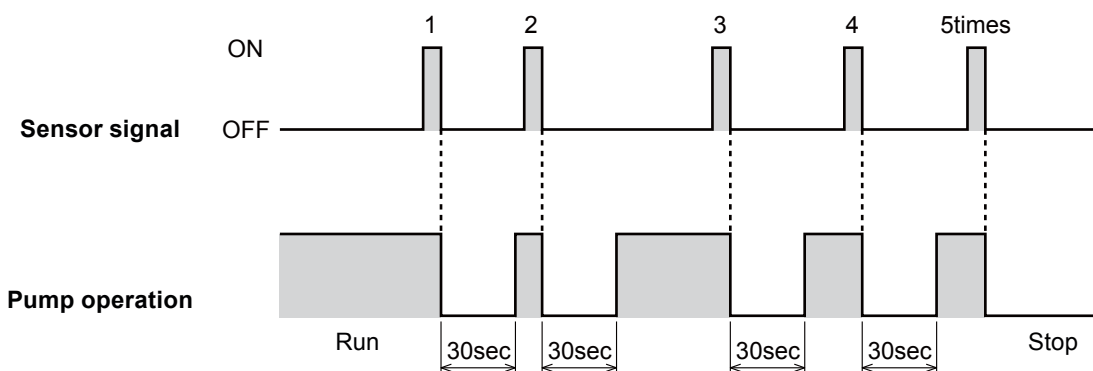

■ Output function (See page 44 & 45)

Set the STOP, Pre-STOP, Interlock, Diaphragm rupture detection and Overload detection outputs to the OUT 1 and OUT2.

See page 31 "Output signal" for wiring diagram.

OUT1: Mechanical relay output

(No voltage contact 1x1 250VAC 3A Resistive load)

OUT2: PhotoMOS relay output

(No voltage contact 1x1 24VAC/DC 0.1A Resistive load)

■ Other functions

Suction speed setting (See page 47)

Suction speed is adjustable by 4 levels.

Select 100%, 75%, 50% or 25%.

Example of use: Viscous liquid transfer

Diaphragm position adjustment (See page 47 & 48)

A pump shaft expands or contracts to help diaphragm replacement.

The pump shaft comes at the top dead centre when stopping operation. Replace a diaphragm and contract the pump shaft, and then mount the pump head.

See page 58 "Diaphragm replacement" for detail.

Anti chattering programming (See page 47 & 48)

Program a pulse recognition time not to be adversely affected by chattering or noise.

Factory default setting is 5msec.

Select 1 or 2msec if a pulse frequency is high.

Flow unit setting (See page 47 & 48)

Select L/H or GPH for flow rate indication.

Part names

Pump

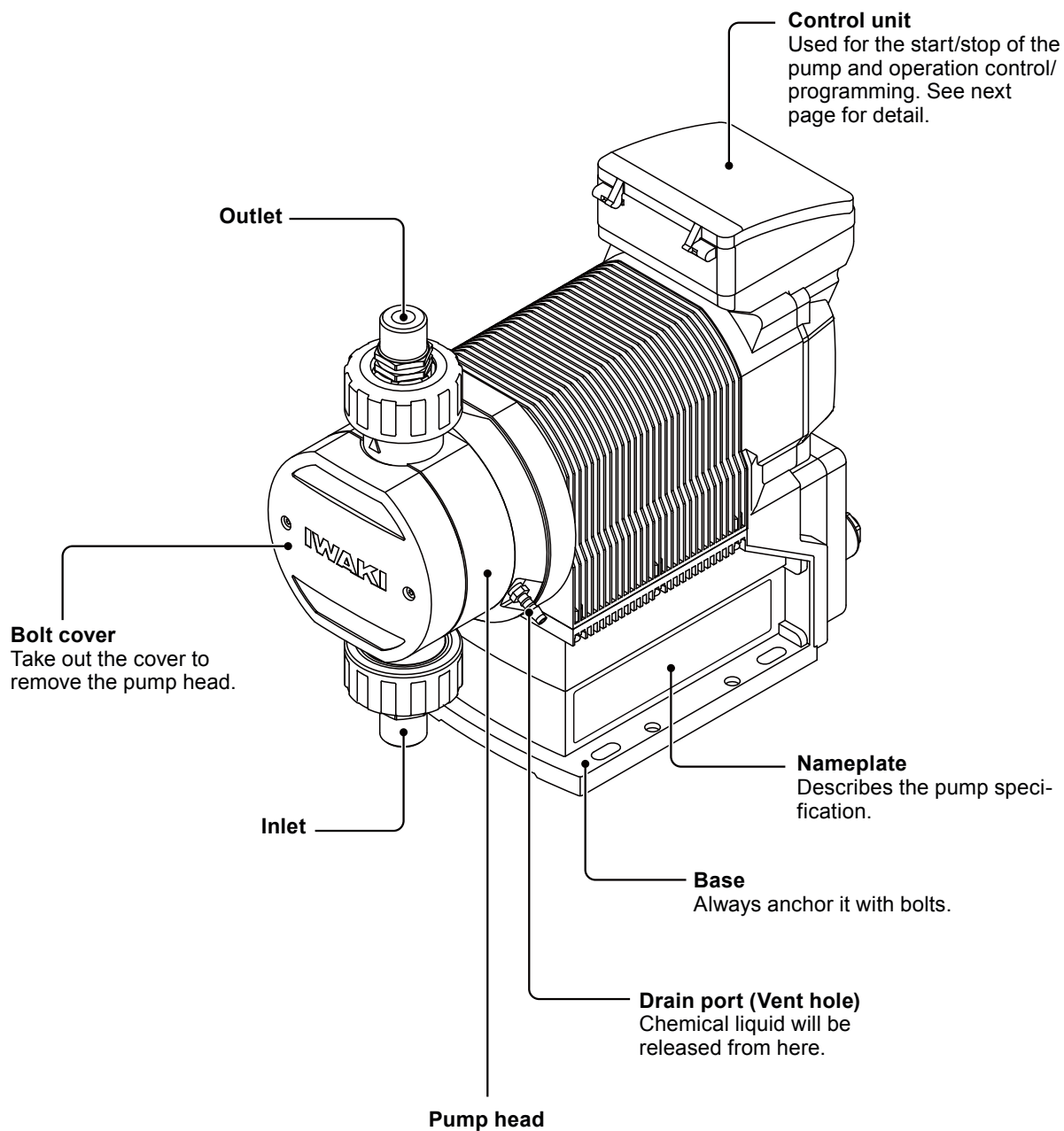

Operation panel

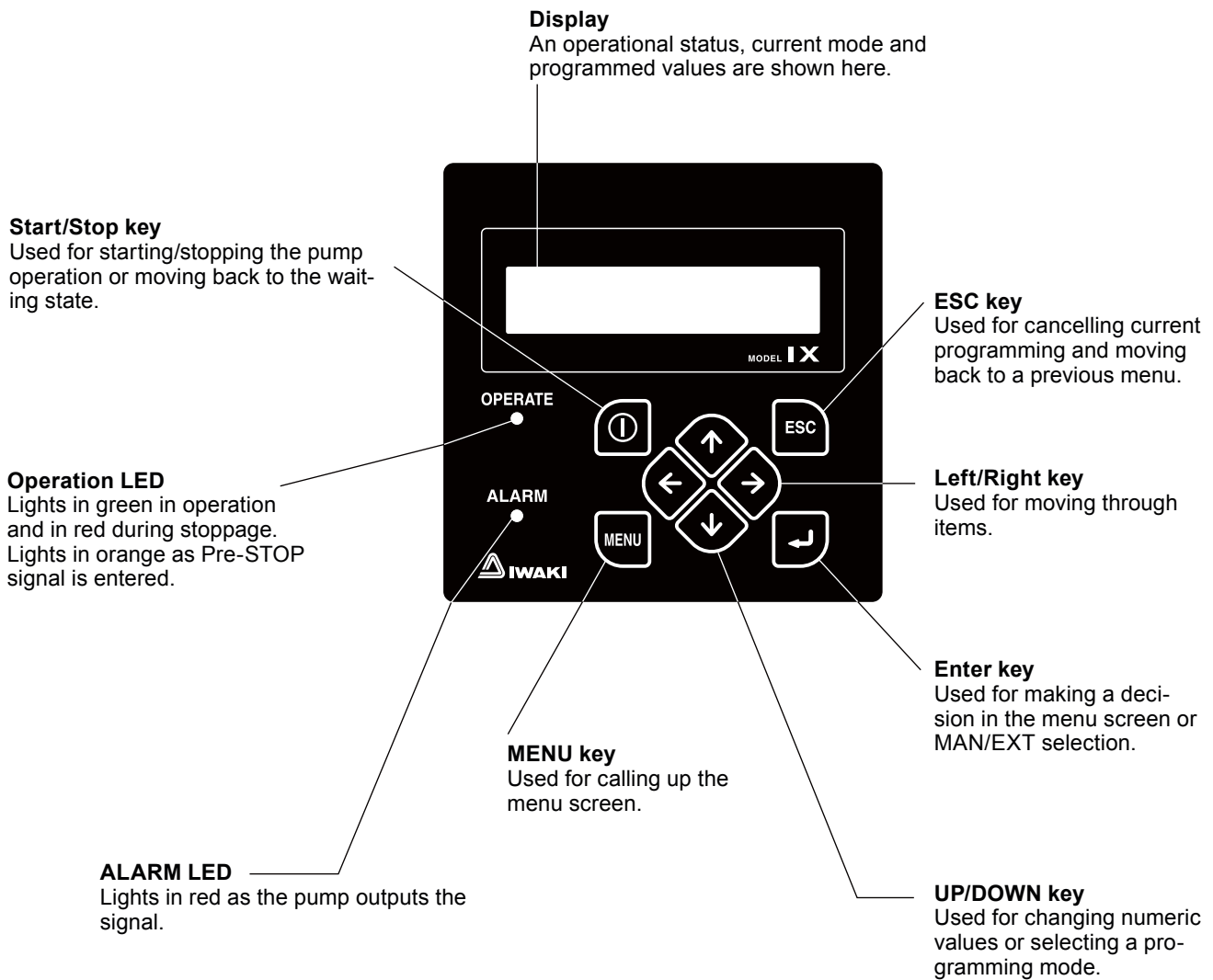

■ Basic displays and Pump states

	Display	Operation LED lights in red.	Operation LED light in green.	Operation LED lights in orange.	ALARM LED lights in red.
Operation	PUMP On (Manual) 150 L/H	—	Operation in manual mode.	Pre-STOP function is active.	STOP or Interlock function is active.
	PUMP On (Analog) 150 L/H	—	Operation in EXT mode (Analogue control).	Pre-STOP function is active.	STOP or Interlock function is active.
	PUMP On (AUX) 150 L/H	—	AUX operation	—	STOP or Interlock function is active.
	PRIMING OVERRIDE @ 150 L/H	—	Operation in priming mode.	—	STOP or Interlock function is active.
Stop	Standby (Manual) 150 L/H	A wait state in manual mode	—	—	STOP function is active.
	Standby (EXT) Analog	A wait state in EXT mode (analogue control)	—	—	STOP function is active.
	SELECT OPERATION MAN ← → EXT (ANALG)	MAN/EXT selection	—	—	STOP function is active.
	MAIN MENU: ← Program EXT →	Menu screen	—	—	STOP function is active.
	MOTOR OVERLOAD! S/S Key = Clear	Overload protection is active.	—	—	Overload protection is active.
	LEAK DETECTED! S/S Key = Clear	Diaphragm is broken.	—	—	Diaphragm is broken.
	DRIVE ERROR! S/S Key = Clear	Sensor failure	—	—	—

Level sensor & interlock information

Stop (Manual*) -----*	STOP function is active.
Pre-Stop (MAN*) 150 L/H*	Pre-STOP function is active.
Interlock (MAN*) -----*	Interlock function is active.

*Information changes with pump states.

Identification codes

Each code represents the following information.

Pump

IX - C 150 TC R - TB □ - E □□
 a b c d e f g h i

a. Series name

b. Drive unit

C

c. Pump unit (Max flow)

150 : 150 [L/H]

d. Wet end materials

Code	Pump head	Diaphragm	Valve ball	Fitting	O ring	Valve gasket
TC	PVDF	PTFE+EPDM	Alumina ceramics	PVDF	FKM	-
S6	SUS316	PTFE+EPDM	SUS316	SUS316	-	PTFE

Material code

- PVDF : Polyvinylidene difluoride
- PTFE : Polytetrafluoroethylene
- EPDM : Ethylene-propylene rubber
- FKM : Fluorine-contained rubber
- SUS316 : Austenitic stainless steel

e. Connection

- R : Thread
- F : Flange

f. Controller housing

- TF : Top Front
- TB : Top Back
- TR : Top Right
- TL : Top Left
- RF : Right Face
- LF : Left Face

g. PROFIBUS

- P : Pumps with profibus
- No code : No profibus

h. Power plug

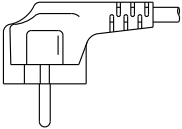
Code	E
Plug shape	 Europe (2m length cord)

i. Special version code

- No code : Standard
- S : Special version

Installation

This section describes the installation of the pump, piping and wiring. Read through this section before work.

! Points to be observed

Observe the following points when installing the pump.

- Be sure to turn off power to stop the pump and related devices before work.
- Upon sensing abnormal condition or a dangerous sign, stop work immediately. Remove problems before resuming work.
- Do not place dangerous or flammable goods near the pump for your safety.
- Risk of an electrical leak or shock. Do not use a damaged pump.

Pump mounting

Select an installation location and mount the pump.

Necessary tools

- Four M8 bolts (pump mounting)
- Adjustable wrench or spanner

1 Select a suitable place

Always fix the pump on a flat floor free of vibrations. See page 10 for detail.

Flooded suction mounting is strongly recommended when using gaseous liquid such as sodium hypochlorite.

2 Anchor the pump by four M8 bolts.

NOTE

Install the pump horizontally. If the pump is installed at a tilt, the flow may reduce.

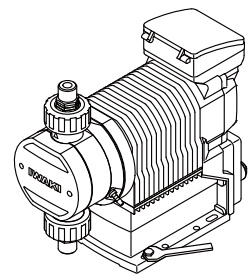

Pipework

■ Piping layout

Flooded suction application

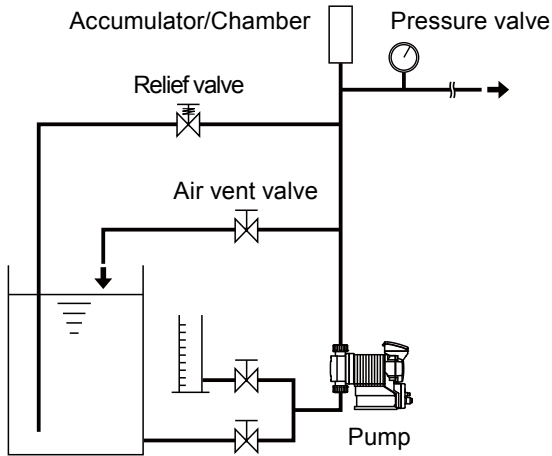

Suction lift application

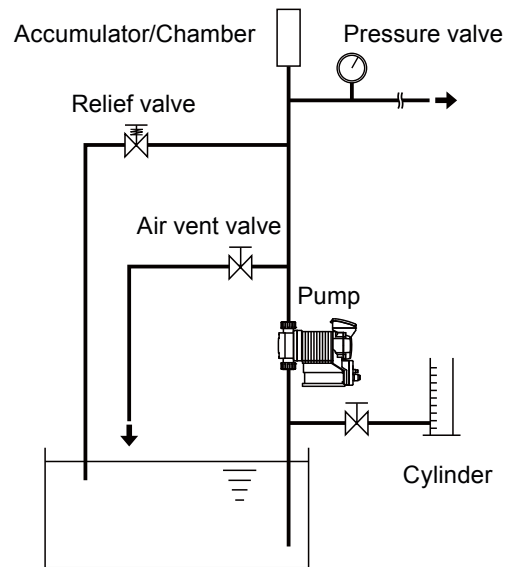

NOTE

- A suction line bore should be wider than the inlet bore of the pump.
- Do not tighten the plastic nut too much, or it may break.
- Flooded suction is recommended when handling a gaseous liquid such as sodium hypochlorite.

Drain port (Vent hole)

*Leaked liquid drains through a drain port at the time of accidental diaphragm rupture.
Use a chemically-resistant tube to the drain port to collect the liquid in a tank.*

NOTE

- Do not plug the drain port. The port functions as a vent hole to keep the pressure in the pump head constant.
- Do not immerse the tube end in liquid, or liquid may be pumped up through the drain port in operation.

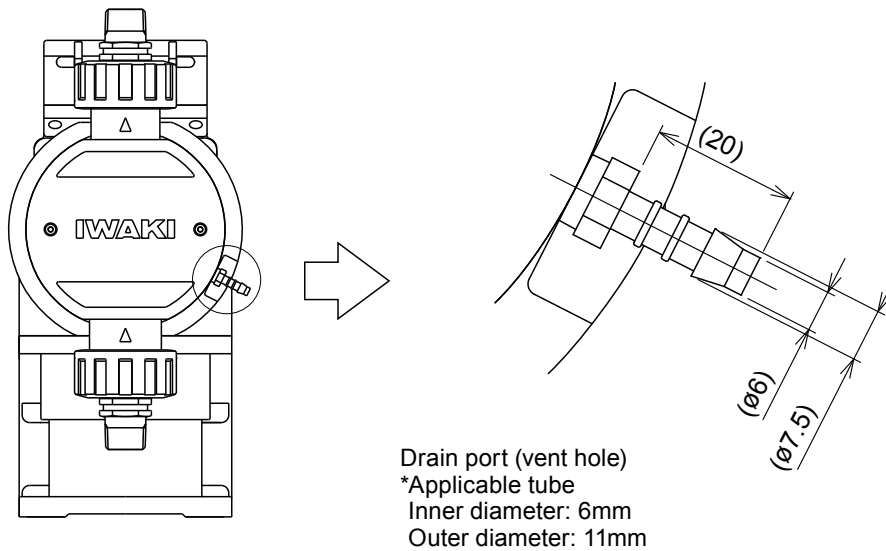

To supply tank or to safe disposal

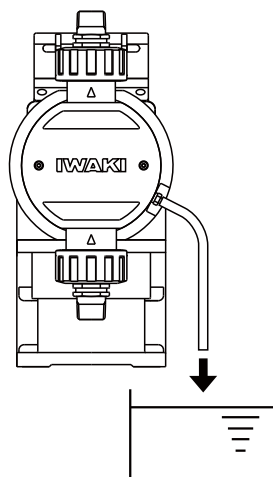

Wiring

Wiring for power supply, earthing and external signals.

! Points to be observed

Observe the following points during wiring work.

- Electrical work should be performed by a qualified operator. Always observe applicable codes or regulations.
- Observe the rated voltage range, or the electrical circuit in the control unit may fail.
- Do not perform wiring work while the power is on. Otherwise, an electrical shock or short circuit may result. Be sure to turn off power before wiring work.
- Be careful for the power not to be turned on during work.
- Replacement of a power cable should be conducted by a manufacturer, his agency or a skilled person. Otherwise, an accident may result.

Necessary tools

- Adjustable wrench or spanner
- Phillips screw driver
- Flathead screw driver
- Precision screw driver

End terminals

See the following diagram for detail.

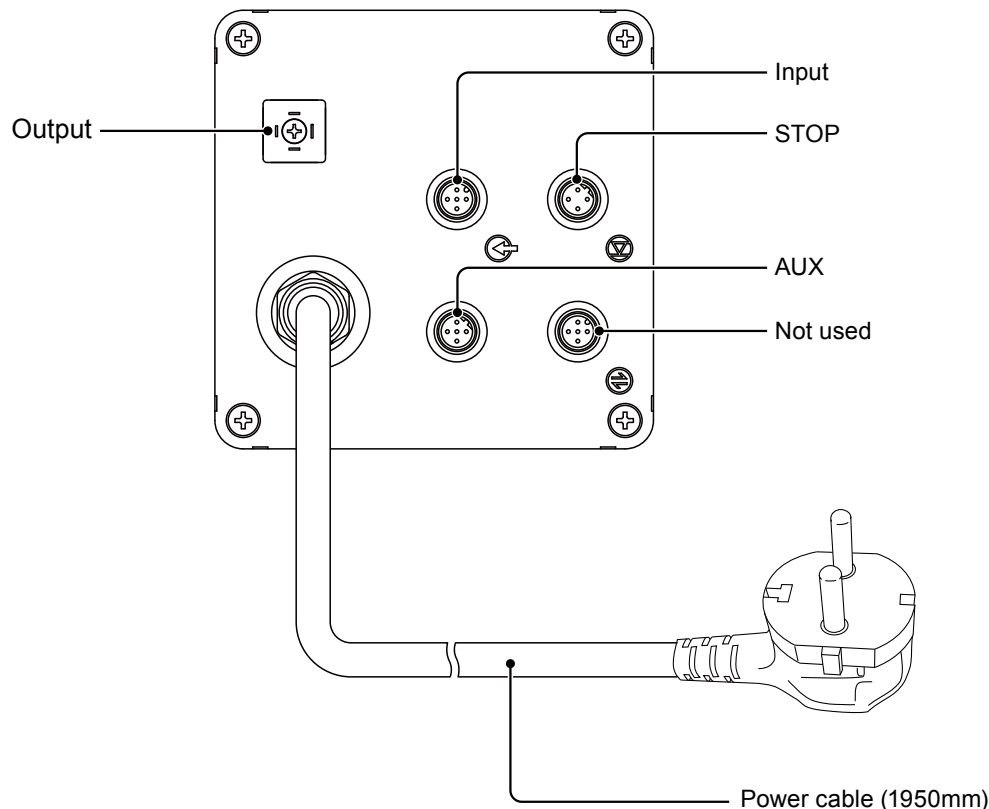

Power supply/Earthing

Points to be checked

- Check that the main power is turned off.

1 Insert the plug all the way seated in a socket.

NOTE

- Do not share a power source with a high power equipment which may generate surge voltage. Otherwise an electronic circuit may fail. The noise caused by the inverter also affects the electronic circuit.
- Power voltage should be charged at a sitting via a switch or a relay. Otherwise CPU may malfunction. See page 29 for the precautions for ON-OFF control by the relay.

When the power is applied at a sitting.

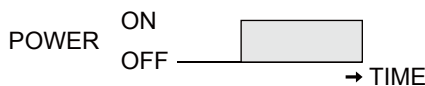

When the power is applied gradually



Surge voltage

The electronics within the pump can be damaged by excessive surges in voltage. Do not install the pump near high-power electrical equipment (200V or more) that generate high surge voltages. Avoid branch circuits that also supply power to heavy or other equipment that could generate electrical interference. If necessary...

- Install a surge suppression device (such as a varistor with a resistance greater than 2000A) or,

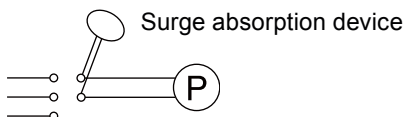

Recommended varistors

Panasonic ERZV14D431

KOA NVD14UCD430

See manufacturer's catalogues for detail.

- A noise reducing transformer at the pump's power connection.

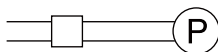

Noise reducing transformer

Precautions for ON-OFF control by the relay

The control unit is equipped with CPU. Always start/stop the pump by the STOP signal. Do not start/stop the pump by turning ON/OFF power because it may adversely affect CPU.

If there is no choice but to turn ON/OFF power, observe the following points.

- Do not turn ON/OFF the power more than six times per hour.
- When using a relay for ON-OFF operation, its contact capacity should be 5A or more. Contact point may fail if contact capacity is less than 5A.
- If the contact capacity of 5A is used, the maximum ON/OFF operation is about 150,000 times. Use the relay with the contact capacity of 10A or more when making ON-OFF operation over 150,000 times or sharing a power source with a large capacity equipment. Otherwise a contact may fail by surge voltage.
- Use a non-contact transistor relay as necessary (such as the OMRON G3F). See manufacturer's catalogues for detail.

Signal wire connection

Points to be checked

- Check that the main power is turned off.

Use our option connector cables or purchase the following DIN 4- and 5-pin female connector cables when using signal input and output.

Binder round connector cables

5-pin : 713 series 99-0436-10-05 Input signal

4-pin : 715 series 99-0430-15-04 Stop signal

5-pin : 715 series 99-0436-15-05 Stop signal

Hirschmann square connector cables

4-pin : GDS307 Output signal

NOTE

- Do not install the EXT/STOP signal wires in parallel with a power cable or combine them in a concentric cable (ex. 5 wires cable). Otherwise noise is generated through the EXT/STOP signal wires due to induction effect and it results in malfunction or failure.
- When using the SSR (Solid State Relay) for the EXT/STOP signal input, see the recommended products below. Any SSR other than the recommended ones can cause malfunction. See manufacturer's information for detail.
 - OMRON G3FD-102S or G3FD-102SN
 - OMRON G3TA-IDZR02S or G3TA-IDZR02SM
- When using a contact type relay for the EXT/STOP signal input, the minimum application load should be 5mA or below.
- Insert the DIN 4- or 5-pin female connector as far as it will go and then tighten the skirt to make a secure connection.

*Use either a no-voltage contact or an open collector for the external signal.

■ STOP signal

To activate STOP function, connect signal wires to the STOP terminal via a DIN 4-pin connector.

When using an open collector...

Pay attention to polarity. STOP (1) and Pre-STOP (2) are plus (+), and COM is minus (-).

When using a contact...

The contact should be designed for an electronic circuit. The minimum application load should be 1mA or less.

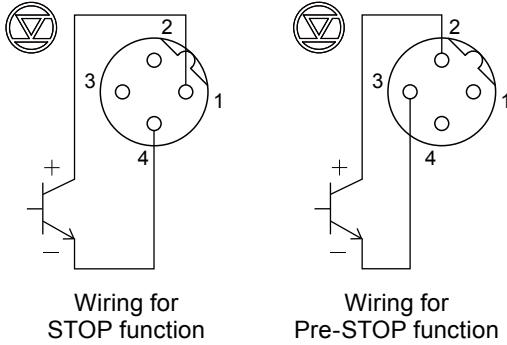

- 1 : STOP (Brown)
- 2 : Pre-STOP (White)
- 3 : COM (Blue)
- 4 : COM (Black)

*Each terminal is coloured as above for our optional cable.

NOTE

- Our option cable has 5 wires. Cut off a green wire to use it with the DIN 4-pin connector.

■ Input signal

To make pulse- and analogue-control operation or to activate interlock function, connect signal wires to the input terminals via a DIN 5-pin connector.

When using an open collector...

Pay attention to polarity. Pulse (1), Analogue (3) and Interlock (2) are plus (+), and COM (4) is minus (-).

When using a contact...

The contact should be designed for an electronic circuit. The minimum application load should be 5mA or less.

When using analogue control...

Pay attention to polarity. Analogue (3) is plus (+) and COM (4) is minus (-).

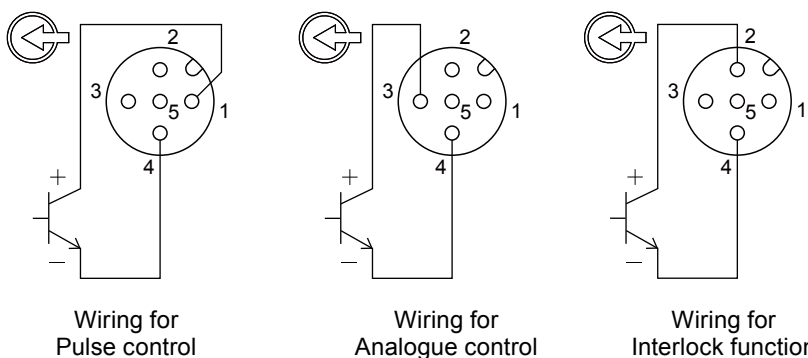

- 1 : Pulse (Brown)
- 2 : Interlock (White)
- 3 : Analogue (Blue)
- 4 : COM (Black)
- 5 : 12VDC30mA or below (Green)

*Each terminal is coloured as above for our optional cable.

■ AUX signal

To activate AUX function, connect signal wires to the AUX terminal via a DIN 5-pin connector.

When using an open collector...

Pay attention to polarity. AUX (3) is plus (+), and COM (4) is minus (-).

When using a contact...

The contact should be designed for an electronic circuit. The minimum application load should be 5mA or less.

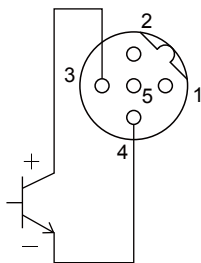

- 1 : N.C.
- 2 : N.C.
- 3 : AUX
- 4 : COM
- 5 : 12VDC30mA or below

Wiring for
AUX function

■ Output signal

To transmit signal to an external device, connect signal wires to the OUT terminal via a DIN 4-pin connector.

OUT1<Mechanical relay>: Enable or disable STOP, Pre-STOP, Interlock, Motor overload and Leak detection individually.

*Leak detection only is enabled at factory default setting.

OUT2<PhotoMOS relay>: Enable or disable STOP, Pre-STOP, Interlock, Motor overload and Leak detection individually.

*Interlock only is enabled at factory default setting.

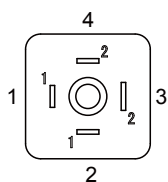

- 1 : OUT1
- 2 : OUT1
- 3 : OUT2
- 4 : OUT2

Operation

This section describes pump operation and programming. Run the pump after pipework and wiring is completed.

Before operation

First check piping and wiring are correct. And then make commissioning before starting operation.

Points to be checked

Before operation, check if...

- Liquid level in the supply tank is enough.
- Piping is securely connected and is free from leakage and clogging
- Discharge/suction valves are opened.
- Specified power voltage is applied to the pump.
- Electrical wiring is correct and is free from short circuit and electrical leakage.

Retightening of pump head fixing bolts

Important

The pump head fixing bolts may loosen when plastic parts creep due to temperature change in storage or in transit.

This can lead to leakage. Retighten the pump head fixing bolts before starting operation.

Always tighten the bolts diagonally. See below for the tightening torque.

Tightening torque

Model code	Torque	Bolts
IX-C150	10 N•m	M8 Hex. socket head bolt

*Tighten fixing bolts once every three months.

Commissioning

Always make commissioning when first mounting the pump in your system or resuming operation after a long period of stoppage.

- 1 Open air vent and suction lines.
Do not open a calibration line if any.

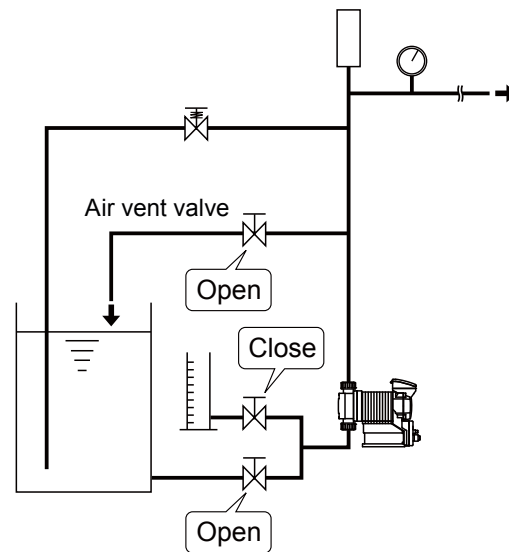

- 2 Turn on power.
- 3 Select manual mode and set the flow rate to 200mL/H.
- 4 Run the pump and increase the flow rate to the maximum.
Continue operation for 10 minutes.
Check the pump and pipework for any abnormality.
- 5 Close an air vent line to pump liquid to a main line.

Before a long period of stoppage (One month or more)

Clean wet ends and the inside of piping.

- Run the pump with clean water for about 30 minutes to rinse chemicals off.

Before unplugging the pump

- Always stop the pump by key operation. And wait for three seconds before unplugging the pump. Otherwise, the last key operation to stop the pump may not be put in memory. In this case the pump unintentionally starts to run as powered on, discharging liquid.

When the pump does not transfer liquid at resuming operation.

- Clean the valve sets. Remove foreign matters.
- If air is in the pump head, expel air through the above commissioning procedure.

Perform a calibration

Periodically make a calibration to monitor an accurate flow through control display. The pump has been calibrated by pumping clean water at the maximum operating pressure before shipping, however, make calibration again in an actual operating condition as necessary. Follow the calibration step on the next page.

NOTE

- The pump does not measure how much volume is being pumped. A flow rate on the screen is calculation value based on calibration and is not an actual flow rate.

Calibration is made for determine liquid volume per shot. Arrange your pump system based on the diagram below.

Suggested piping layout

Use a calibration cylinder.

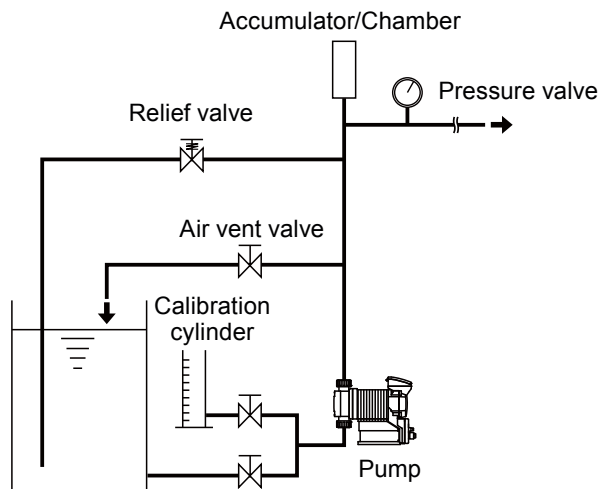

Bad example

Do not immerse a calibration tube in a liquid level in a calibration cylinder. Tube volume is added to the liquid volume to be measured, and calibration will be upset.

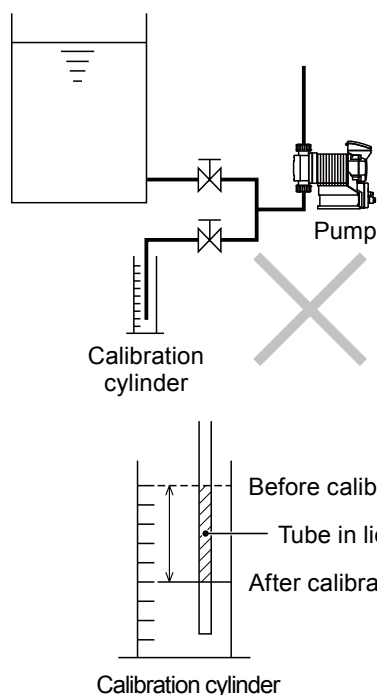

Calibration process

Run the pump at the stroke rate of an actual duty point and obtain an accurate flow rate.

- 1 Fill a calibration cylinder with liquid.
Open a calibration line to lead liquid from a supply tank to a calibration cylinder. And then close the suction line and measure liquid volume in the cylinder.

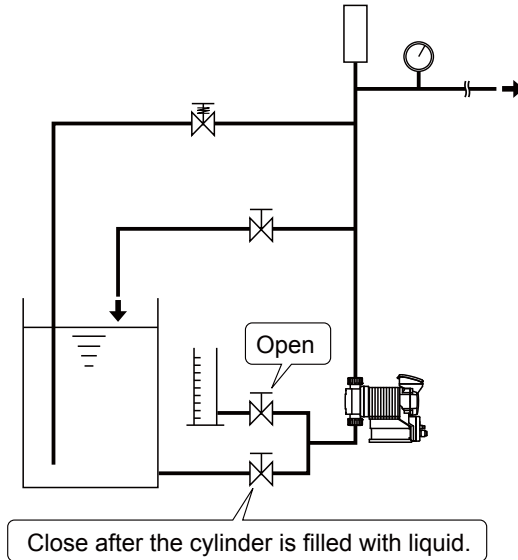

- 2 Select the calibration mode through the menu screen and push the Enter key.
See page 39 for detail.

- 3 Calibration operation programming
Set a waiting time to start and the number of strokes.

Waiting time [Setting range: 10-999s]
Number of strokes [Setting range: 60-120ST]

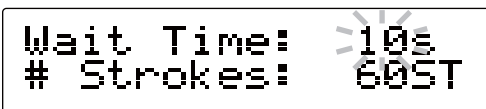

Use UP and DOWN keys to set a waiting time as necessary.
Push the Enter key and move to the next setting.

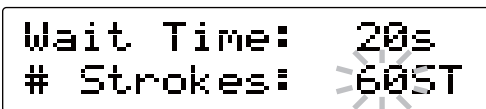

Use UP and DOWN keys to set the number of strokes.

4 Start calibration operation.

```
Wait Time: 20s
# Strokes: 100ST
```

```
20
:
19
:
18
:
17
```

Push the Enter key after setting the number of strokes. The pump starts a countdown.



```
Wait Time: 0s
# Strokes: 100ST
```

```
Pump
starts
```

The pump starts to run for the set number of strokes as it comes to zero.



```
Wait Time: 0s
# Strokes: 99ST
```

```
99
:
98
:
97
```



```
Wait Time: 0s
# Strokes: 0ST
```

```
Pump
stops
```

5 Measure liquid volume in the calibration cylinder again.

6 Enter how much liquid volume reduces.

```
Enter Volume:
              0 mL
```

Use UP and DOWN keys to set the volume reduction.
*The screen shows "ERROR! Volume Out Of Range!!" if the set value is out of range. Enter collect liquid volume.



```
Enter Volume:
              1650 mL
```



```
Volume/Stroke:
              16.50mL
```

Push the Enter key once. The screen shows a flow rate per shot. Calibration is now has been completed.



```
MAIN MENU:
← Calibration →
```



```
SELECT OPERATION
MAN← →EXT(ANALG)
```

Push the ESC key to return to waite mode.

Operation programming

The pump operation is programmed and controlled by a control unit in different ways at each operation mode.

Mode	Parameters	Setting ranges	Default
Mode selection	-	MAN/EXT	MAN
External control	Analogue control	0-20mA/ 4-20mA/ 20-0mA/ 20-4mA	4-20mA
	Pulse control	0.0156mL/PLS-300mL/PLS	0.01560mL/PLS
	Batch control	15.6mL/PLS-300L/PLS	15.6mL/PLS
	Interval Batch control	0-9day, 0-23Hr, 1-59min 15.6mL-300L	0D : 0H : 1M 15.6mL
Signal input	STOP	Closed = Pump OFF/ Closed = Pump ON	Closed = Pump OFF
	PreSTOP	Closed = Pump OFF/ Closed = Pump ON	Closed = Pump OFF
	Interlock	Closed = Pump OFF/ Closed = Pump ON	Closed = Pump OFF
	Lead detection	Enable/ Disable	Enable
Alarm	Alarm 1	STOP/ Pre-STOP/ Interlock Leak Detection/ Motor Overload	Leak Detection
	Alarm 2	STOP/ Pre-STOP/ Interlock Leak Detection/ Motor Overload	Interlock
Others	Suction speed	100%/ 75%/ 50%/ 25%	100%
	Flow rate in AUX operation	200mL/H - 150L/H	150L/H
	Diaphragm position	MAX OUT Pos./ MAX IN Pos.	MAX OUT Pos.
	Anti-Chattering	1msec/ 2msec/ 5msec	5msec
	Unit	Liter/ US. Gallon	Liter

*A value increases/decreases step by step as pushing the UP/DOWN keys. Press and hold either key for quick change.

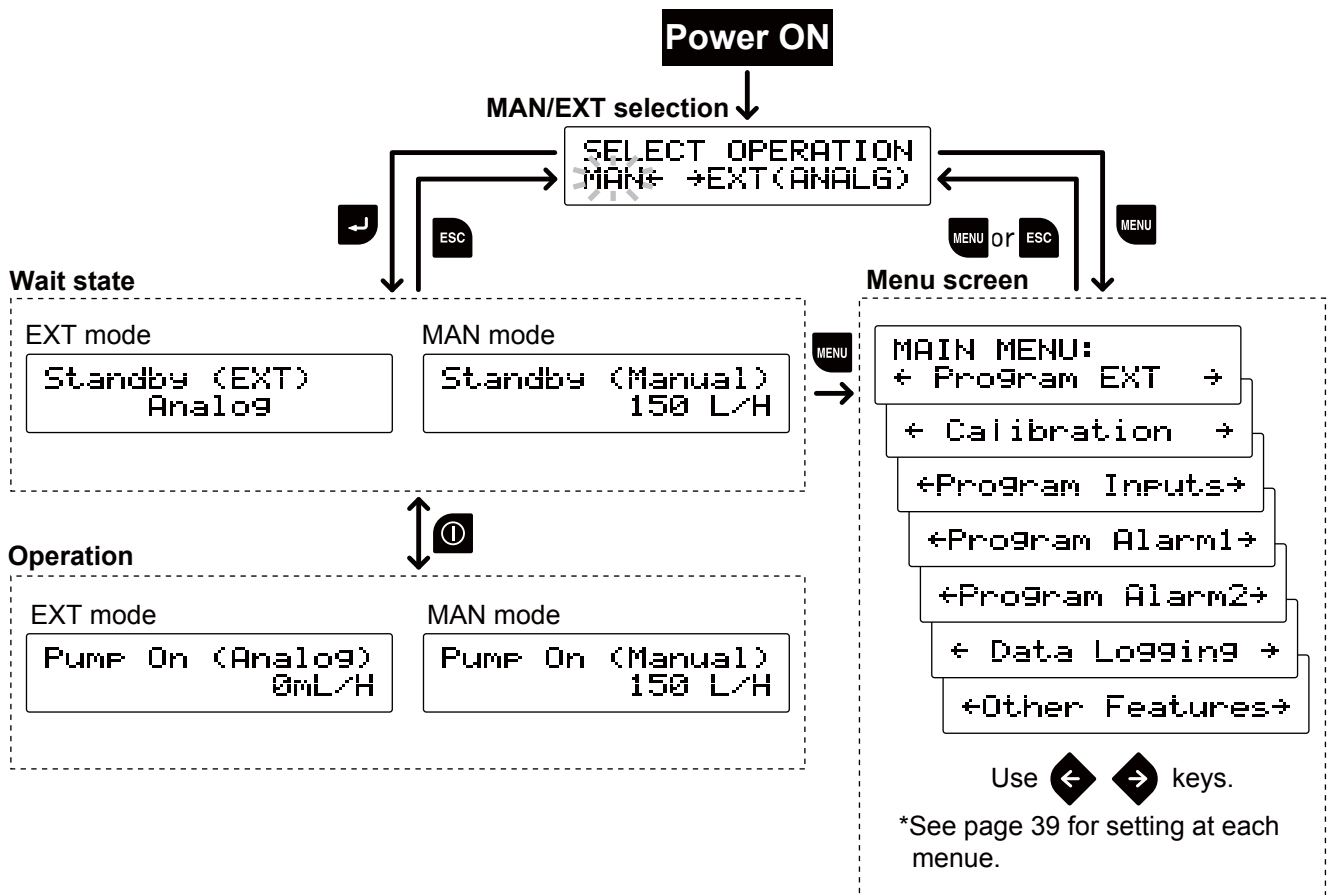

Menu screen

Push the MENU key while the MAN/EXT selection display appears and call up the menu screen.

Push the MENU or ESC key to return to the MAN/EXT selection mode.

```
MAIN MENU:  
← Program EXT →
```

EXT mode selection

The pump can run in four different operating modes of Analog, Pulse, Batch and Interval Batch for the external signal. See page 40.

```
MAIN MENU:  
← Calibration →
```

Calibration

Calibrate the pump to obtain a correct flow rate on the screen. See page 42.

```
MAIN MENU:  
←Program Inputs→
```

Signal input setting

Program STOP, Pre-STOP & Interlock functions and diaphragm rupture detection. See page 42.

```
MAIN MENU:  
←Program Alarm1→
```

Alarm 1 setting

Enable or disable the Alarm 1 for STOP, Pre-STOP, Interlock and/or diaphragm rupture detection. See page 44.

```
MAIN MENU:  
←Program Alarm2→
```

Alarm 2 setting

Enable or disable the Alarm 2 for STOP, Pre-STOP, Interlock and/or diaphragm rupture detection. See page 45.

```
MAIN MENU:  
← Data Logging →
```

Data logging

The pump can display operating time, total flow volume, power-on time, the number of ON/OFF and software version. See page 46.

```
MAIN MENU:  
←Other Features→
```

Programming of other functions.

Program a suction speed, a flow rate in AUX operation, diaphragm position, anti-chattering and flow rate unit. See page 47.

Use the left and right keys to scroll through the items and then push the Enter key to make a selection.

■ EXT mode selection

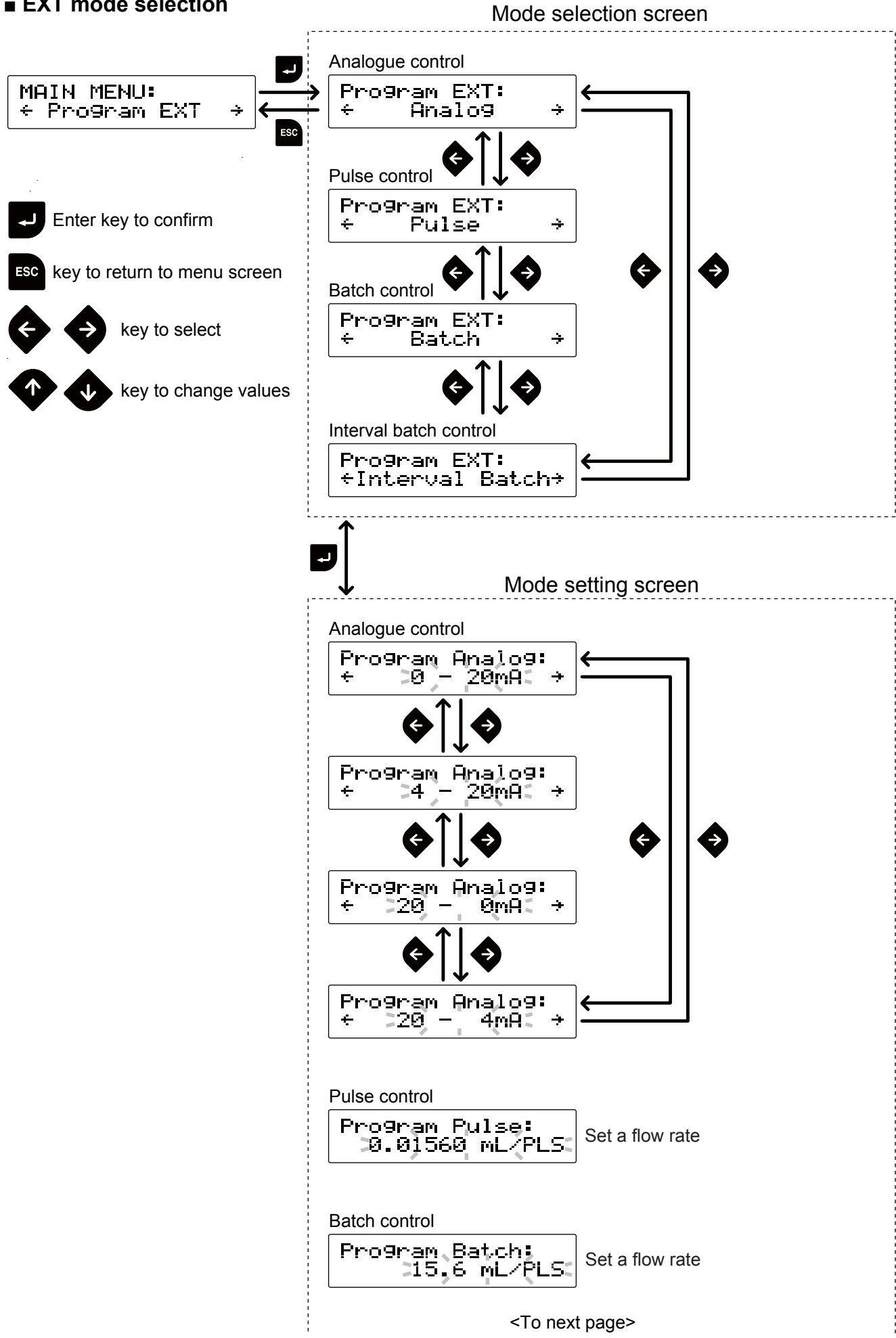

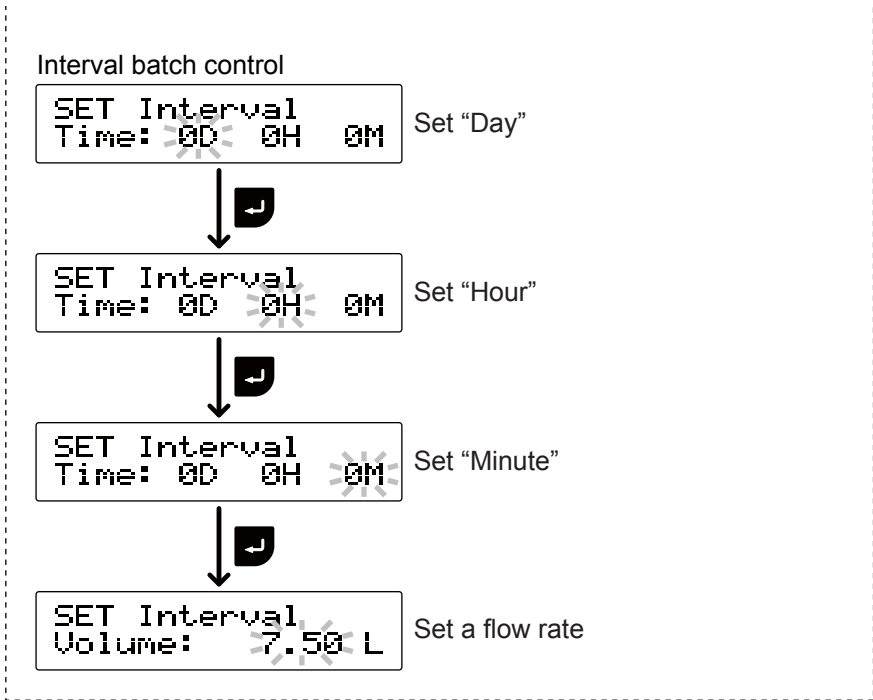

■ Calibration

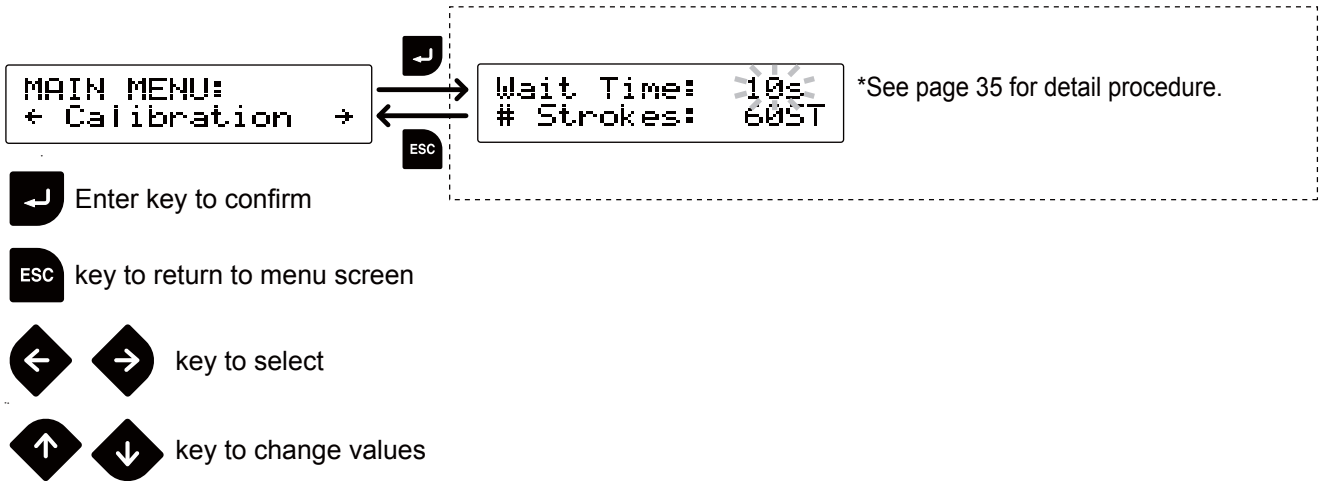

■ Signal input setting

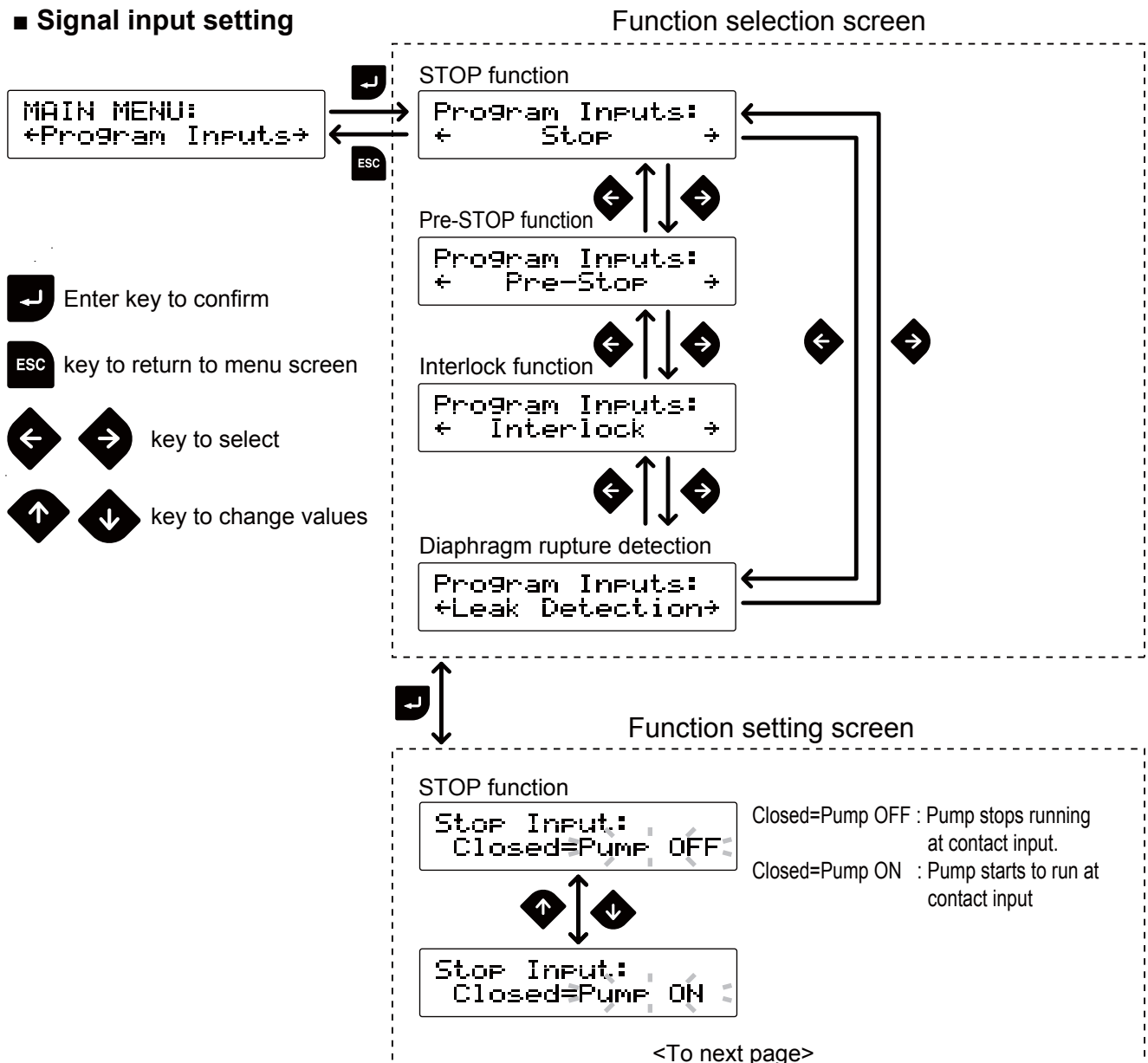

Pre-STOP function

```
Pre-Stop Input:  
Closed=Pump OFF
```

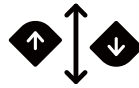

```
Pre-Stop Input:  
Closed=Pump ON
```

Closed=Pump OFF : Operation LED lights in orange at contact input
Closed=Pump ON : Operation LED does not lights at contact input.

Interlock function

```
Interlock:  
Closed=Pump OFF
```



```
Interlock:  
Closed=Pump ON
```

Closed=Pump OFF : Pump stops running at contact input.
Closed=Pump ON : Pump starts to run at contact input

Diaphragm rupture detection

```
Leak Detection:  
Disable
```



```
Leak Detection:  
Enable
```

Disable : Rupture detection is not used.
Enable : Rupture detection is used.

Alarm 1 setting

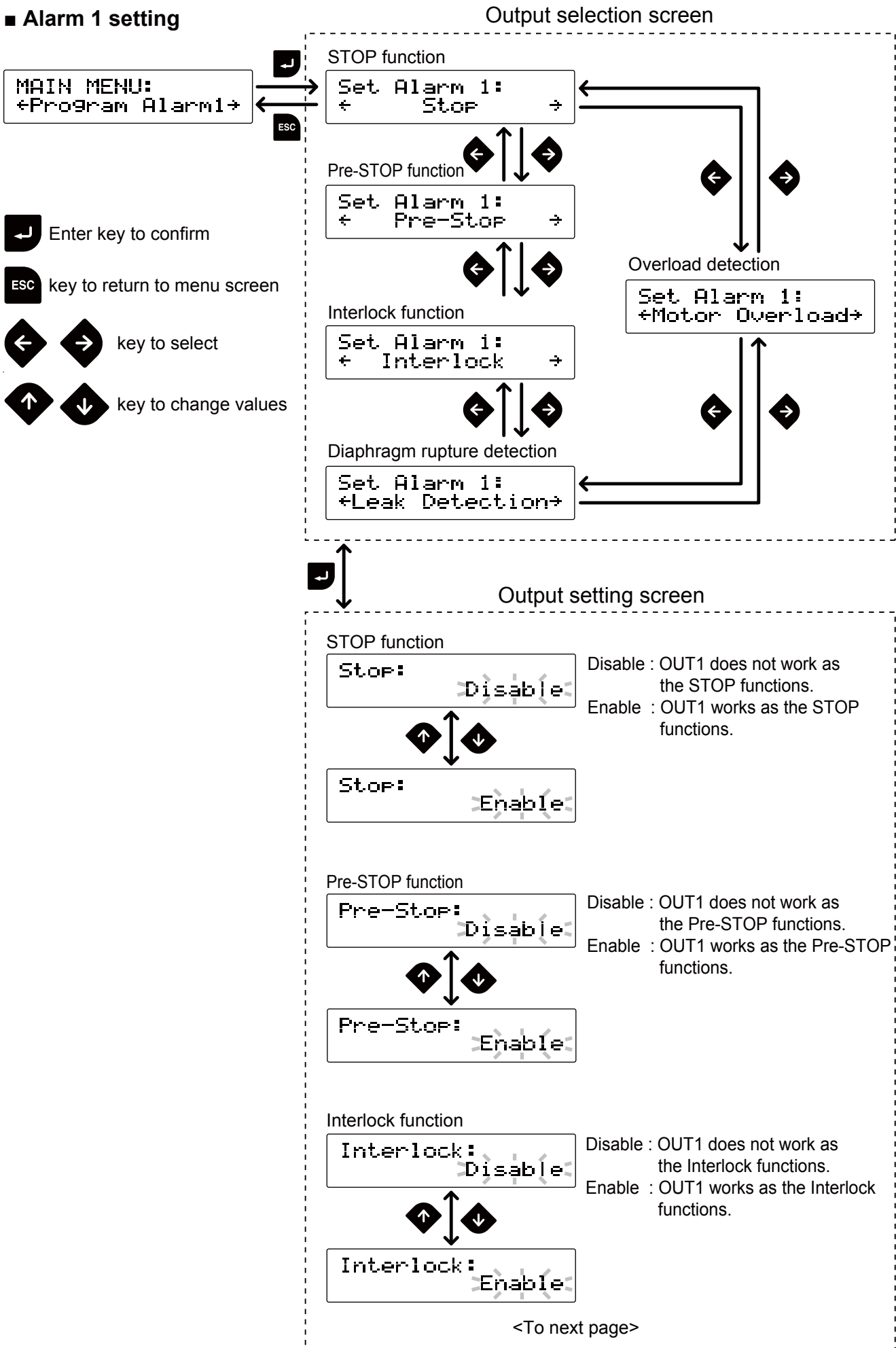

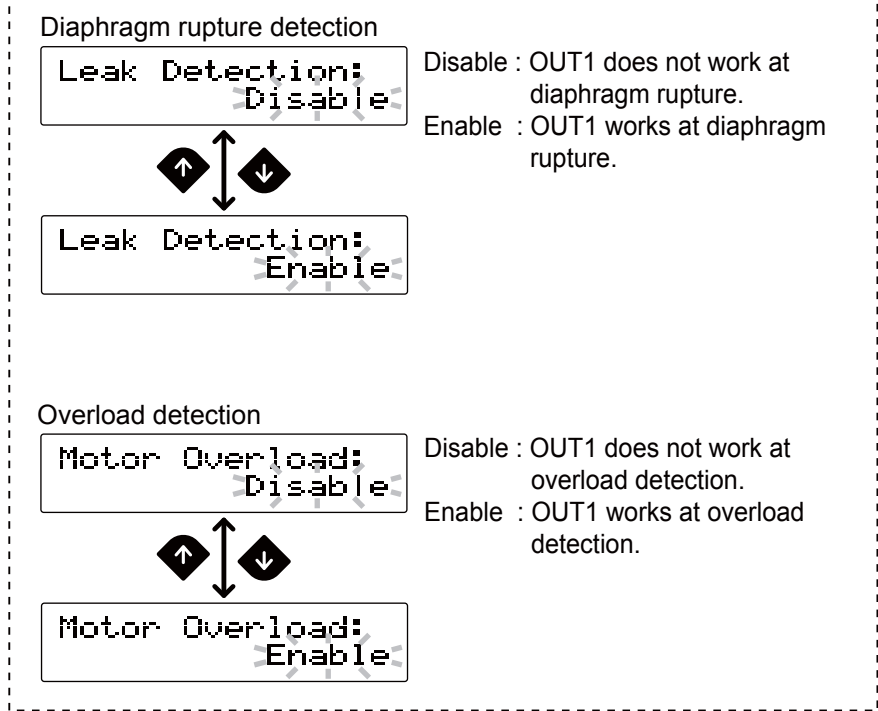

■ Alarm 2 setting



Alarm 2 is programmed in the same way as the Alarm1.
The difference between two alarms is the Alarm 2 is a PhotoMOS relay while Alarm 1 is a mechanical relay.

■ Data logging

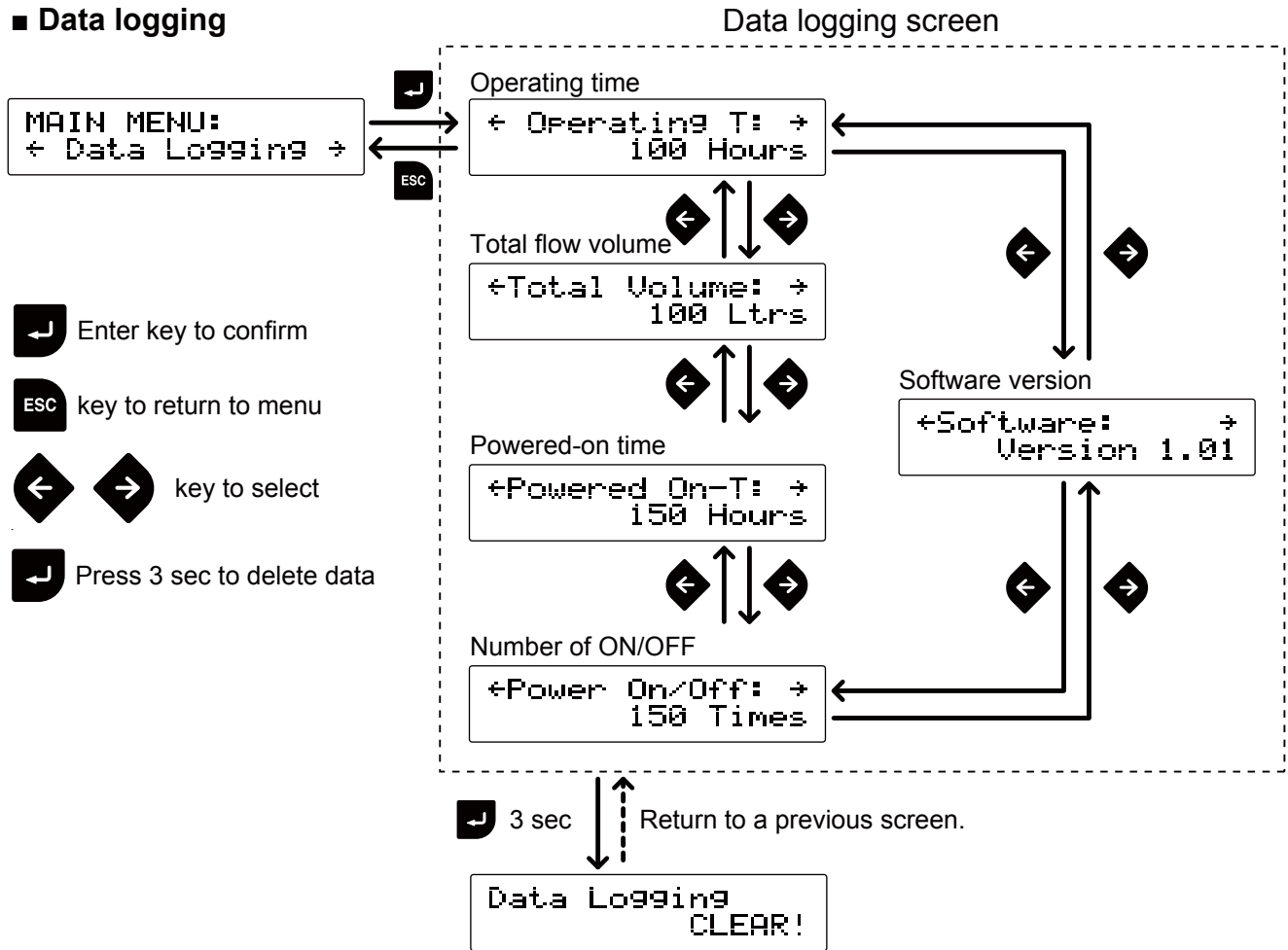

*A selected data will be cleared.

*Version information will not be cleared.

■ Programming of other functions

Other selection screen

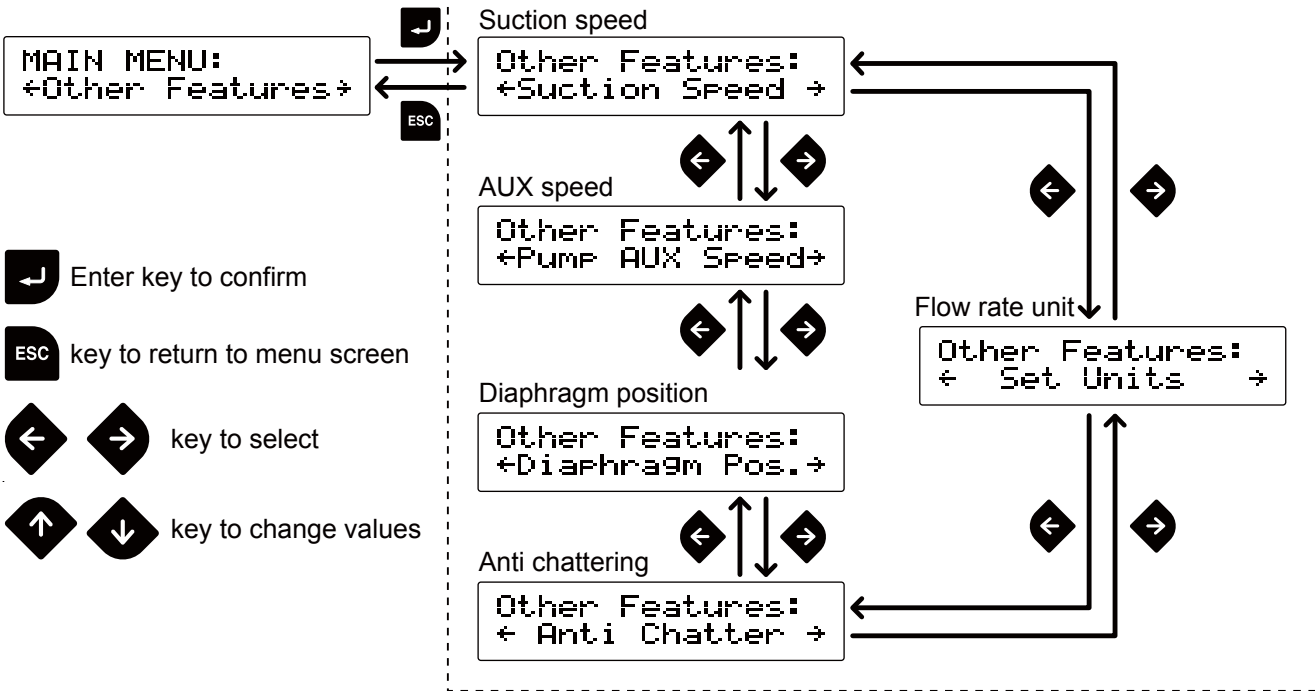

Other setting screen

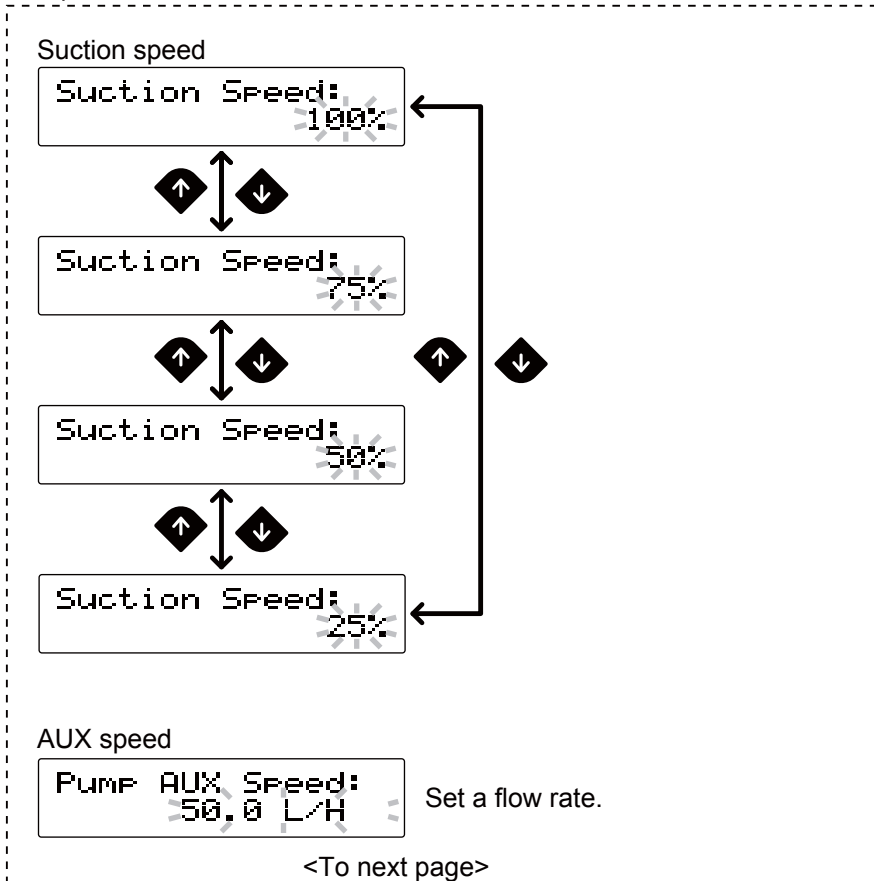

Operation

Diaphragm position

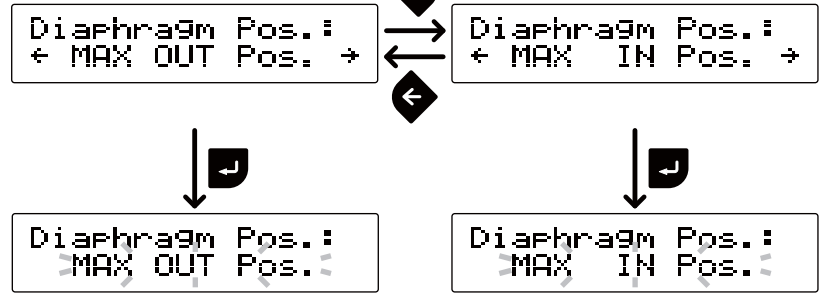

MAX OUT Pos. : The diaphragm comes to the top dead point.
MAX IN Pos. : The diaphragm comes to the bottom dead point.
Either one of the above indication keeps flashing as long as the diaphragm is at either end. Push the Enter key to return.

Anti chattering

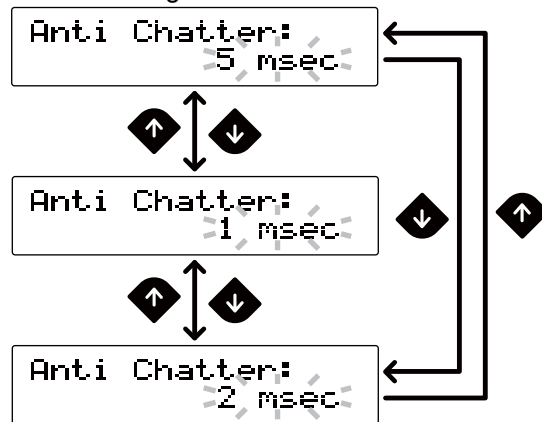

Flow rate unit

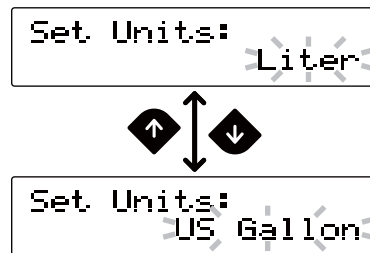

Operation

Read this section before operation.

EXT operation

The pump operation is controlled by the external signal.

1 Turn on power.

The operation LED lights in red colour and a display related to the current operating state appears on the screen.

*The pump enters the MAN/EXT selection mode when turning on power with a default setting. The pump calls up the last screen at a shutoff if it was not in a default setting.

2 Enter MAN/EXT selection mode.

Push the ESC key to enter the selection mode.

```
SELECT OPERATION
MAN← →EXT(ANALG)
```

3 Push the right key to select EXT and the Enter key to enter that choice.

```
SELECT OPERATION
MAN← →EXT(ANALG)
```



```
Standby (EXT)
Anal09
```

Waiting state display

*The pump enters Analogue, Pulse, Batch or Interval Batch mode.

4 Push the start/stop key to start operation. Pushing the key again to stop operation.

```
PUMP On (Anal09)
    0 mL/H
```

The pump runs along with operation programming.
The operation LED turns green during operation.

Manual operation

Run or stop the pump by keypad operation.

- 1 Select MAN in MAN/EXT selection mode.

```
SELECT OPERATION
MAN ← → EXT (ANALG)
```

- 2 Push the Enter key once.

The pump enters a waiting state.

Use the UP and DOWN keys to set a flow rate.

```
Standby (Manual)
      150 L/H
```

- 3 Push the start/stop key to stop operation.

The operation LED lights in green colour during operation.

```
Pump On (Manual)
      150 L/H
```

Priming function

This key operation runs the pump at the maximum stroke rate in operation.

- 1 Press and hold both UP and DOWN keys.

The pump runs at the maximum stroke rate while both the keys are pressed.

*This function is available at any time except when the pump is in the MAN/EXT selection or menu screen.

```
PRIMING OVERRIDE
      @ 150 L/H
```

- 2 Press and hold both the keys for 10 seconds to leave the pump in this state. Push the start/stop key once to stop operation.

```
PRIMING OVERRIDE
      @ 150 L/H
```

This display will flash after 10 seconds.

Maintenance

This section describes troubleshooting, maintenance, wear part replacement, exploded views and specification.

! Points to be observed

Observe the following points during wiring work.

- Observe instructions in this manual for maintenance, inspection, dismantlement and assembly. Do not dismantle the pump beyond the extent of the instructions.
- Always wear protective clothing such as an eye protection, chemical resistant gloves, a mask and a work cap during dismantlement, assembly or maintenance work.
- Be sure to turn off power to stop the pump and related devices before work. See below.

Before unplugging the pump

Always stop the pump by key operation. And wait for three seconds before unplugging the pump. Otherwise, the last key operation to stop the pump may not be put in memory. In this case the pump unintentionally starts to run as powered on, discharging liquid.

NOTE

- We do not assure material suitability in a specified application and are not responsible for any failure due to corrosion or erosion.
- Contact your distributor for repair or contact a manufacturer of the host machine which our product is built in.
- Be sure to drain chemicals and clean the inside of the pump before return so that a harmful chemical does not spill out in transit.

Troubleshooting

First check the following points. If the following measures do not help remove problems, contact your distributor.

■ Pump

States	Possible causes	Solutions
The pump does not run (The operation LED does not appear or the screen is blank.).	Power voltage is too low.	<ul style="list-style-type: none"> Recover the power voltage to a normal level. Allowable voltage range: 90-264VAC
	The pump is not powered.	<ul style="list-style-type: none"> Check the switch if it is installed. Correct wiring. Replace a breaking wire to new one.
Liquid can not be pumped up.	Air lock in the pump	<ul style="list-style-type: none"> Expel air. See page 33.
	Air ingress through suction line.	<ul style="list-style-type: none"> Reroute piping.
	An O ring is not fitted to a valve set.	<ul style="list-style-type: none"> Fit O ring to the valve set.
	Foreign matters are stuck in the pump head valves.	<ul style="list-style-type: none"> Dismantle, inspect and clean the valve. Replace as necessary.
	A ball valve is stuck on a valve seat.	<ul style="list-style-type: none"> Dismantle, inspect and clean the valve. Replace as necessary.
A flow rate fluctuates.	Air stays in the pump head.	<ul style="list-style-type: none"> Expel air. See page 33.
	Overfeeding occurs.	<ul style="list-style-type: none"> Mount a back pressure valve to keep a level of discharge line pressure.
	Foreign matters are stuck in the pump head valves.	<ul style="list-style-type: none"> Dismantle, inspect and clean the valve. Replace as necessary.
	Diaphragm is broken.	<ul style="list-style-type: none"> Replace diaphragm. See page 57.
	Pressure fluctuates at an injection point.	<ul style="list-style-type: none"> Maintain a pressure constant at an injection point by optimizing piping or by relocating the point.
Liquid leaks.	A fitting is loose.	<ul style="list-style-type: none"> Tighten the nut to fix the fitting.
	Loose fit of the pump head.	<ul style="list-style-type: none"> Retighten the pump head. See page 32.
	An O ring is not fitted to a valve set.	<ul style="list-style-type: none"> Fit O ring to the valve set. See page 56.
	Diaphragm is broken.	<ul style="list-style-type: none"> Replace diaphragm. See page 57.
	A leak from the drain port (Vent hole)	
	Discharge pressure is too high.	<ul style="list-style-type: none"> Check that a discharge line is not closed. Check if piping is not clogged.

Inspection

Perform daily inspection and periodic inspection to keep pump performance and safety.

Daily inspection

Check the following points. Upon sensing abnormal condition, stop operation immediately and remove problems according to "Troubleshooting".

When wear parts come to the life limit, replace them by new ones. Contact your distributor for detail.

No.	States	Points to be checked	How to check
1	Pumping	• If liquid is pumped.	Flow meter or visual inspection
		• If discharge pressure is normal.	Check specification.
		• If liquid is deteriorated, crystallized or settled?	Visual or audio inspection
2	Noise and vibration	• If abnormal noise or vibration occurs. They are signs of abnormal operation.	Visual or audio inspection
3	Air ingress from pump head joints and a suction line	• If leakage occurs. • If pumped liquid includes air bubbles, check lines for leakage and retighten as necessary.	Visual or audio inspection

Periodic inspection

Retighten the pump head mounting bolts diagonally according to the following torque.

*Mounting bolts may loosen in operation. How fast the bolts start to loosen is depending on operating conditions.

Tightening torque

Model identification code	Torque	Bolts
IX-C150	10 N•m	M8 hex. socket head bolt

Wear parts replacement

To run the pump for a long period, wear parts need to be replaced periodically. It is recommended that the following parts are always stocked for immediate replacement. Contact your distributor for detail.

! Precautions

- When dismantling the pump, pay attention to the residual liquid in the pump.
- Rinse wet ends thoroughly with tap water.
- Each time the pump head is dismantled, replace the diaphragm and valve sets with new ones.

Wear part list

	Parts	# of parts	Estimated life
Valve set (TC type)		2 sets	O ring (7&8) 4000 hours Valve seat (4) 8000 hours Valve (2) Seat holder (5&6) Valve guide (3) 24000 hours
Diaphragm		1	4000 hours

*Wear part duration varies with the pressure, temperature and characteristics of the liquid.

*The estimated life is calculated based on pumping clean water at ambient temperature.

Before replacement

First release the pressure from the pump.

1 Stop pump operation.

2 Open the drain valve to release the discharge line pressure.

NOTE

Chemicals may be purged with air if the discharge line pressure is too high.

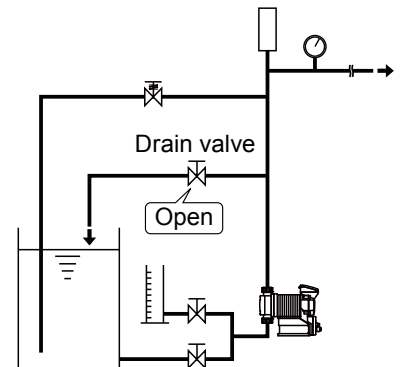

3 Close the suction line.

NOTE

Always close the suction line in flooded suction application. Or chemicals may flow out as a pipe is removed.

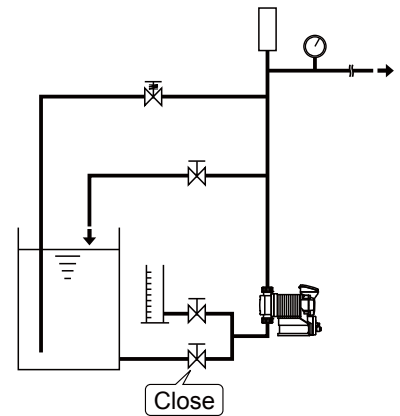

Valve set replacement

■ Discharge line

1 Unfix the pump base.

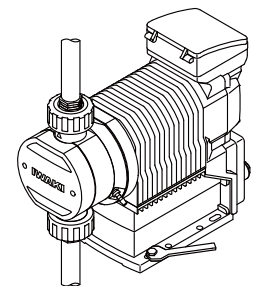

2 Loosen the nut and remove the discharge pipe from the pump.

NOTE

- Be careful not to get wet with residual chemicals in piping.
- Rinse off chemicals or crystals as necessary.

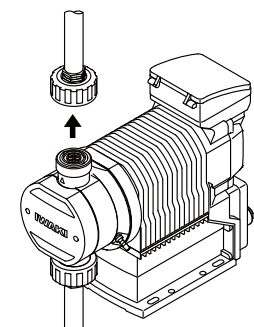

- 3 Take out the valve set from the pump head.
Clean the outlet of the pump head as necessary.

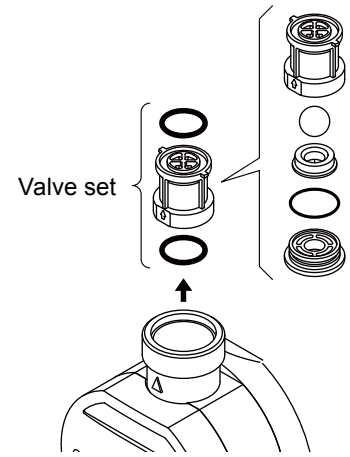

- 4 Take apart the valve set. Replace wear parts as necessary.

- 5 Mount the valve set in the pump head.

- 6 Connect the pipe to the fitting and then tighten the nut.

■ Suction line

- 1 Loosen the nut and remove the suction pipe from the pump.

NOTE

- The valve set may come down as the suction pipe is removed. Take care not to drop it.
- Be careful not to get wet with residual chemicals in the pump head.
- Rinse off chemicals or crystals as necessary.

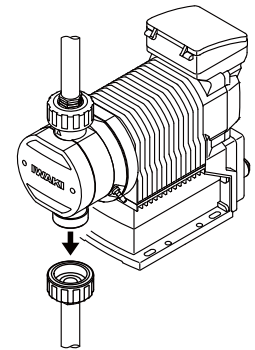

- 2 Take out the valve set from the pump head.
Clean the inlet of the pump head as necessary.

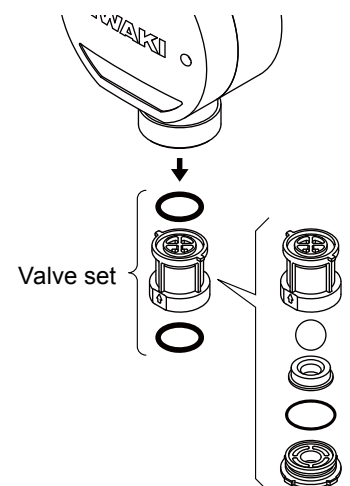

- 3 Take apart the valve set. Replace wear parts as necessary.

- 4 Mount the valve set in the pump head.

- 5 Connect the pipe to the fitting and then tighten the nut.

Diaphragm replacement

Necessary tools

- Hexagon wrench (3mm)
- Adjustable wrench or spanner (13mm)
- Torque wrench

1 Loosen the nuts and disconnect piping.

NOTE

- The valve set may come down as the suction pipe is removed. Take care not to drop it.
- Be careful not to get wet with residual chemicals in the pump head or discharge piping.

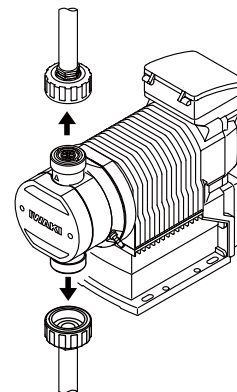

2 Remove the bolt cover by a hexagon wrench.

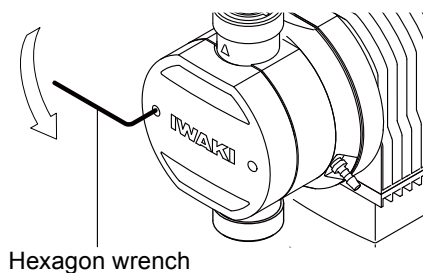

3 Use an adjustable wrench or spanner to remove 8 pump head fixing bolts and detach the pump head with a reinforcing plate.

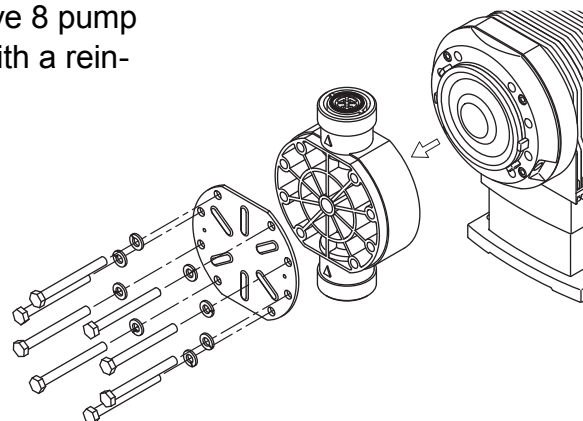

4 Rotate and remove the diaphragm with the retainer.

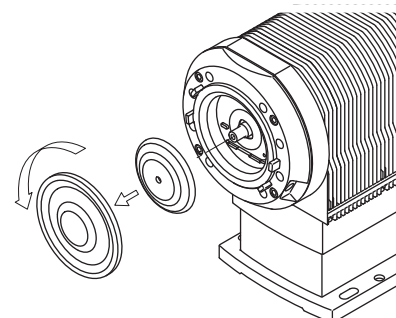

5 Clean the surface of the retainer and apply grease (Dow Corning Toray MOLYKOTE® HP-500). Apply screw burning protective agent to the diaphragm shaft.

6 Fit a new diaphragm and the retainer into the pump shaft.

7 Retract the pump shaft by keypad operation.

Other Features:
←Diaphragm Pos.→



Diaphragm Pos.:
← MAX OUT Pos. →



Diaphragm Pos.:
← MAX IN Pos. →



Diaphragm Pos.:
MAX IN Pos.

Select "Diaphragm Pos." through the menu screen and push the Enter key.
See page 47 for detail.

Select "MAX IN Pos." and push the Enter key. The diaphragm contracts and "MAX IN Pos." appears and blinks on the screen.

8 Mount the pump head.

Always tighten the bolts diagonally by 10N•m.

NOTE

Check the pump shaft has contracted at a maximum before mounting the pump head, or a leak or failure may result. Fix the bolt cover by a hexagon wrench.

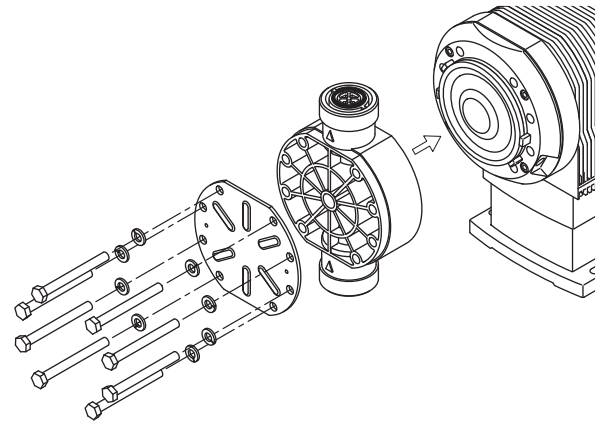

9 Fix the bolt cover by a hexagon wrench.

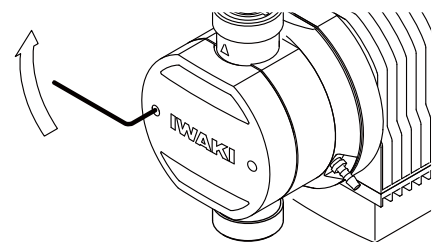

10 Connect pipes to the fittings and then tighten the nuts.

NOTE

Check if the valve sets have been installed before connecting piping.

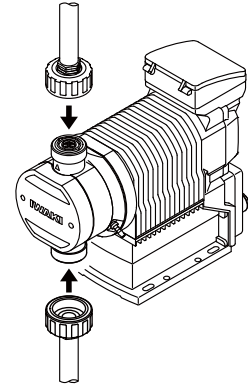

11 Go back to the waiting state.

Other Features:
←Diaphragm Pos.→

Push the Enter key once to shift to the right display.



SELECT OPERATION
MAN← →EXT(ANALG)

Push the start/stop key to return to the MAN/EXT selection.

Exploded view

Pump head, Drive unit & Control unit

Do not dismantle the pump beyond the extent shown in the diagram below.

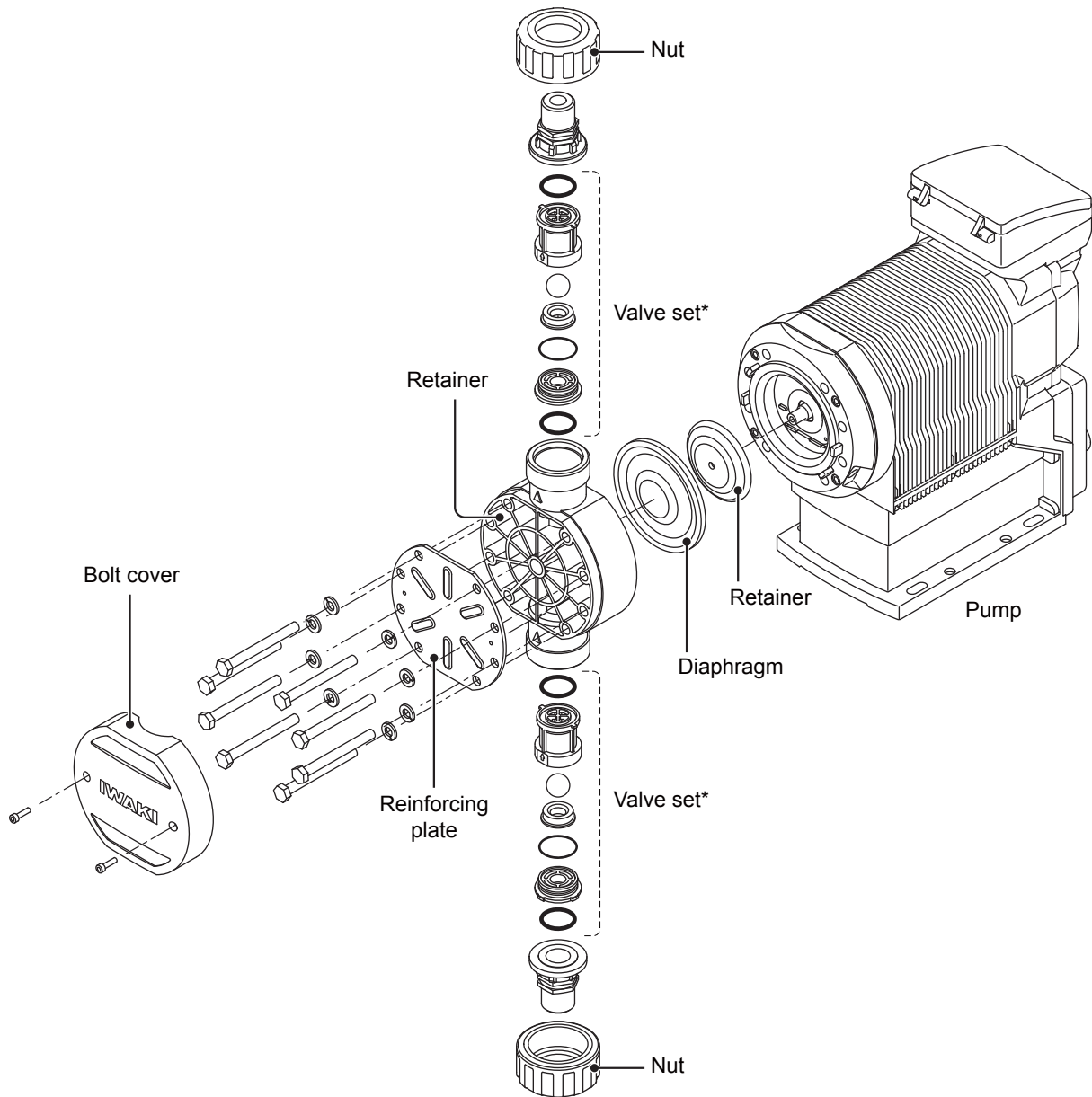

*Pump head material and size differ with models.

Pump

■ IX-C150TCR

No.	Part names	# of parts
1	Pump head	1
2	Valve	2
3	Valve guide	2
4	Valve seat	2
5	Out seat holder	1
6	In seat holder	1
7	O ring	4
8	O ring	2
19	Hex socket head bolt	2
20	Hex head bolt	8
21	Spring washer	8
28	Bolt cover	1
29	Reinforcing plate	1
30	Diaphragm	1
31	Retainer plate	1
50	Nut	2
73	Fitting	2

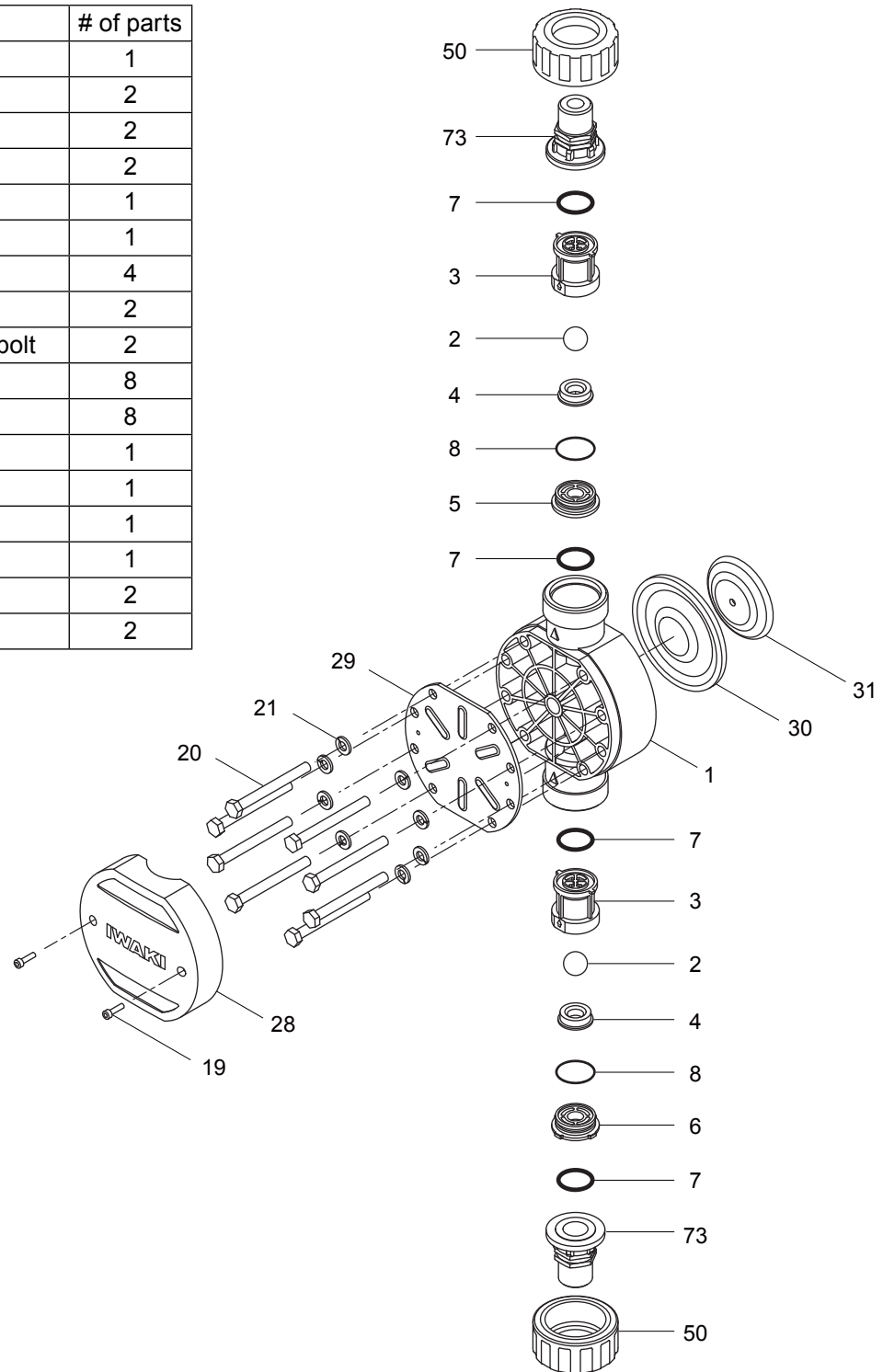

■ IX-C150TCF

No.	Part names	# of parts
1	Pump head	1
2	Valve	2
3	Valve guide	2
4	Valve seat	2
5	Out seat holder	1
6	In seat holder	1
7	O ring	4
8	O ring	2
19	Hex socket head bolt	2
20	Hex head bolt	8
21	Spring washer	8
28	Bolt cover	1
29	Reinforcing plate	1
30	Diaphragm	1
31	Retainer plate	1
45	Flange unit	2

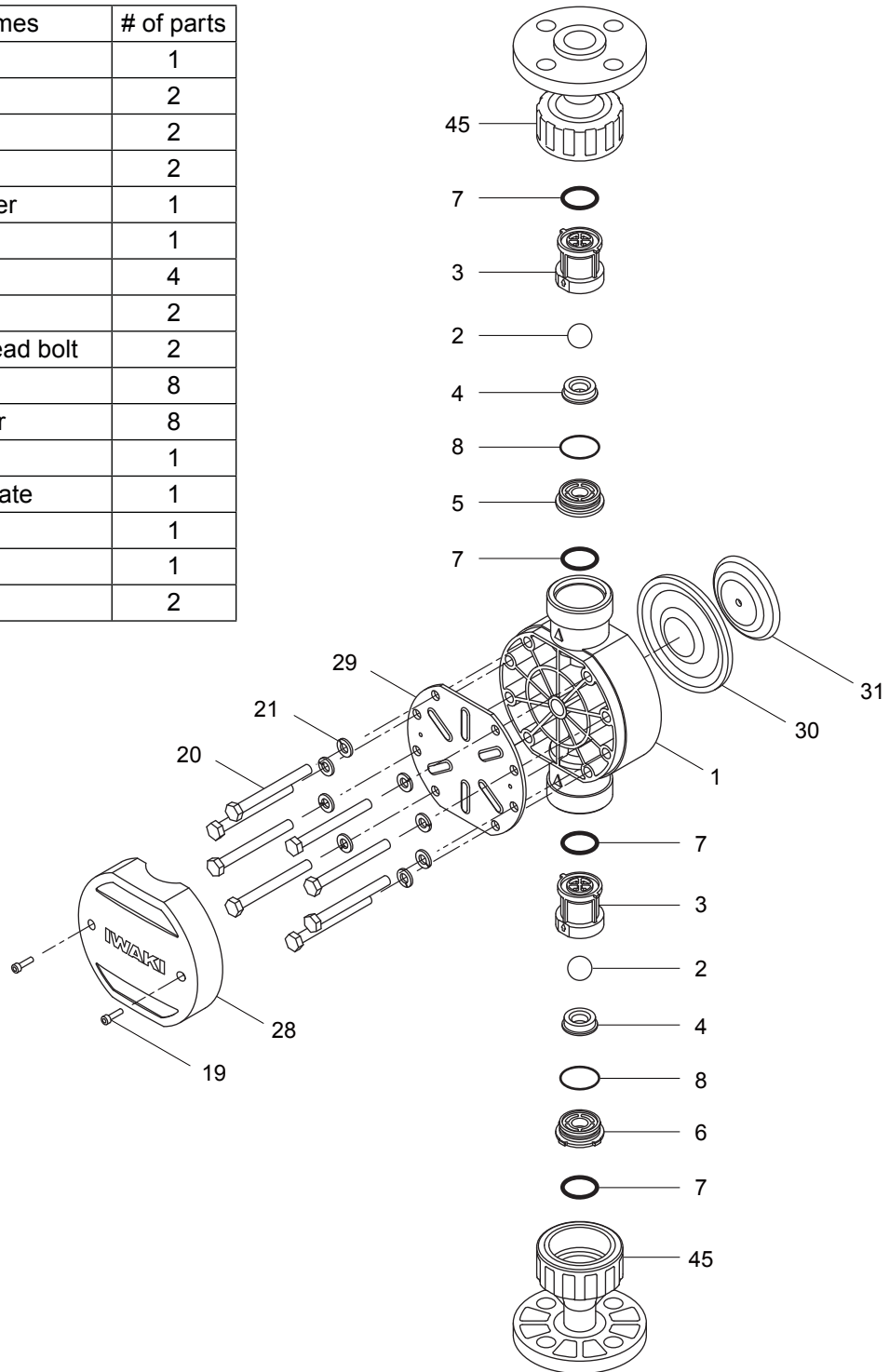

Specification/Outer dimension

Specification

Information in this section is subject to change without notice.

■ Pump

TC type

Identification code	Flow rate L/H	Maximum discharge pressure MPa	Average power consumption W	Current value A	Weight kg
IX-C150TC	0.2 - 150	0.4	62	0.8	9
IX-C150S6	1.0 - 150				12

*The above information is based on pumping clean water at rated voltage and ambient temperature.

*Flow rate is collected at the maximum discharge pressure and increases as a discharge pressure decreases.

*Allowable room temperature: 0-50°C

*Allowable liquid temperature: 0-50°C (TC), 0-80°C (S6)

*Allowable voltage deviation: Within ±10% of rated voltage

*Ambient humidity: 30-90%RH (Non condensing)

■ Control unit

Operation mode	MAN (Manual)	200mL/H - 150L/H	
	EXT	Analogue control	4-20/ 0-20/ 20-4/ 20-0mA
		Pulse control	0.01560mL/PLS - 300mL/PLS
		Batch control	15.6mL/PLS - 300L/PLS
	Interval batch control	0-9day, 0-23Hr, 1-59min 15.6mL - 300L	
Monitors	LCD	16×2 backlit LCD	
	LED	OPERATE	Lights in green colour during pump operation.
			Lights in orange colour when a Pre-STOP signal is input.
			Lights in red colour when the pump has stopped or flashes when over-load is detected.
ALARM	Lights in red colour when OUT1 or OUT2 is activated.		
Operation	Key-pads	Ⓛ(Start/Stop), MENU, ESC, ↵(Enter), ↑(Up), ↓(Down), ←(Left) and →(Right) keys	
Control function	STOP	Operation stop at contact input*1	
	PRIME	Max spm operation by pressing the UP and DOWN keys Press and hold both keys for 10 seconds and then release the keys to leave the pump in this state. Push the start/stop key once to return.	
	Interlock	Operation stop at contact input*1	
	AUX	Operation resumption at contact input	
Input	Stop/ Pre-STOP	No-voltage contact or open collector*2	
	AUX	No-voltage contact or open collector*2	
	Interlock	No-voltage contact or open collector*2	
	Analogue	0-20mADC (Internal resistance is 200Ω.)	
	Pulse	No-voltage contact or open collector (Max pulse frequency is 100Hz.)*3	
Output	Alarm1	No voltage contact (Mechanical relay) 250VAC 3A (Resistive load) Enable or disable STOP, Pre-STOP, Interlock, Leak Detection and Motor Overload. Leak Detection only is enabled in default setting.	
	Alarm2	No voltage contact (PhotoMOS relay) 24VAC/DC 0.1A (Resistive load) Enable or disable STOP, Pre-STOP, Interlock, Leak Detection and Motor Overload. Interlock only is enabled in default setting.	
	Power supply	12VDC 30mA or below	
Power voltage*4		100-240VAC 50/60Hz	

*1 The setting can be changed to "operation resumption at contact input".

*2 The maximum applied voltage to the contact is 12V at 2.3mA. When using a contact closure type switch, the minimum application load should be 2.3mA or below.

*3 The maximum input pulse frequency is 100Hz and is lowered through anti-chattering programming.

*4 Observe the specified power voltage range. Otherwise failure may result. The allowable power voltage range is 90-264VAC.

■ Power cable

Sectional area	0.75 [mm ²] (Triplex cable)	Standard	H03VVF
Length	2000 [mm]	Terminal treatment	Power cable: Spade terminal (V1.25-YS4A or equivalent) Earth : Bared

■ Body colour

Blue	Munsell colour system 7.5PB 3/8
------	---------------------------------

Outer dimension

■ IX-C150TCR-TF

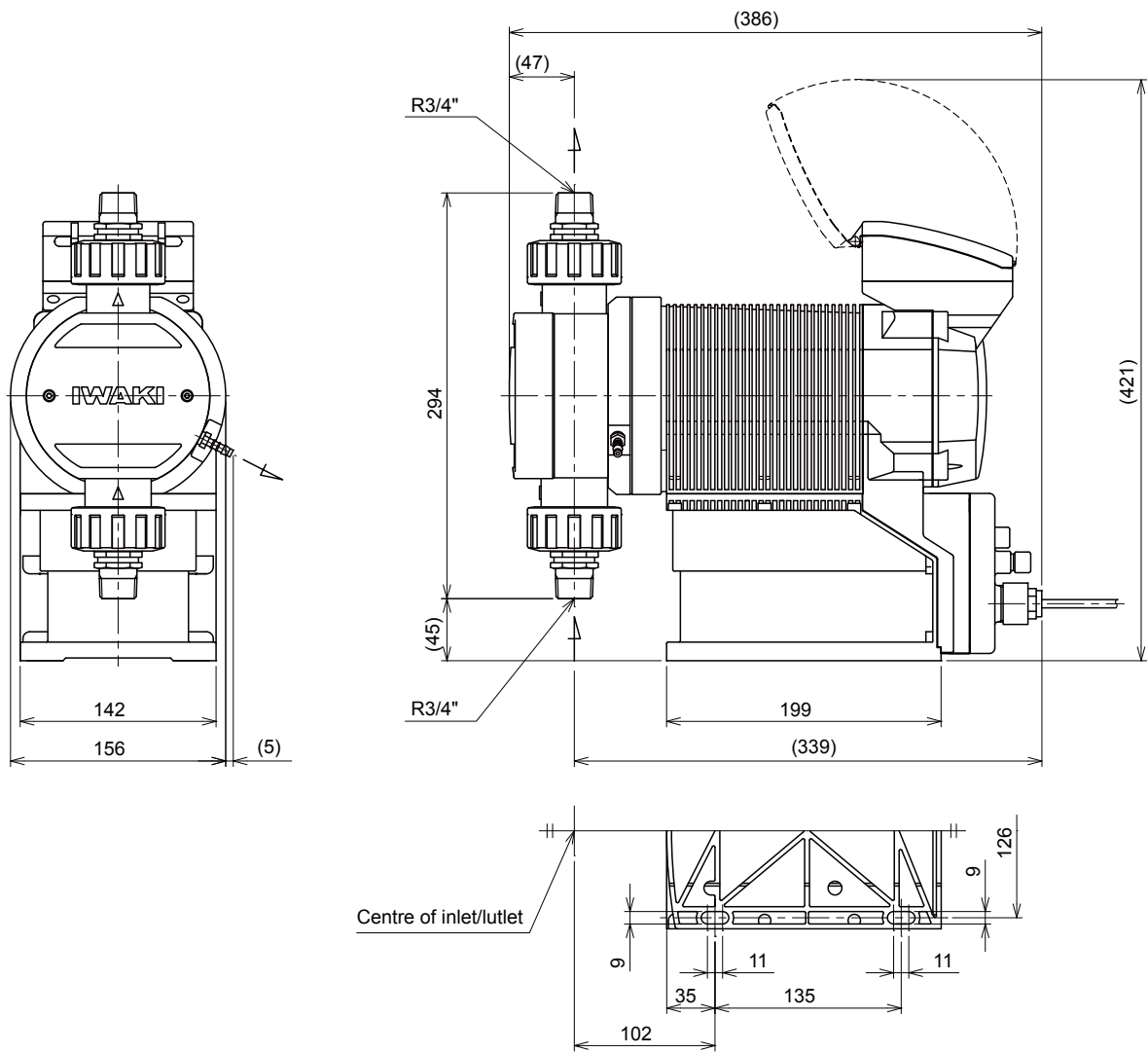

■ IX-C150TCR-RF

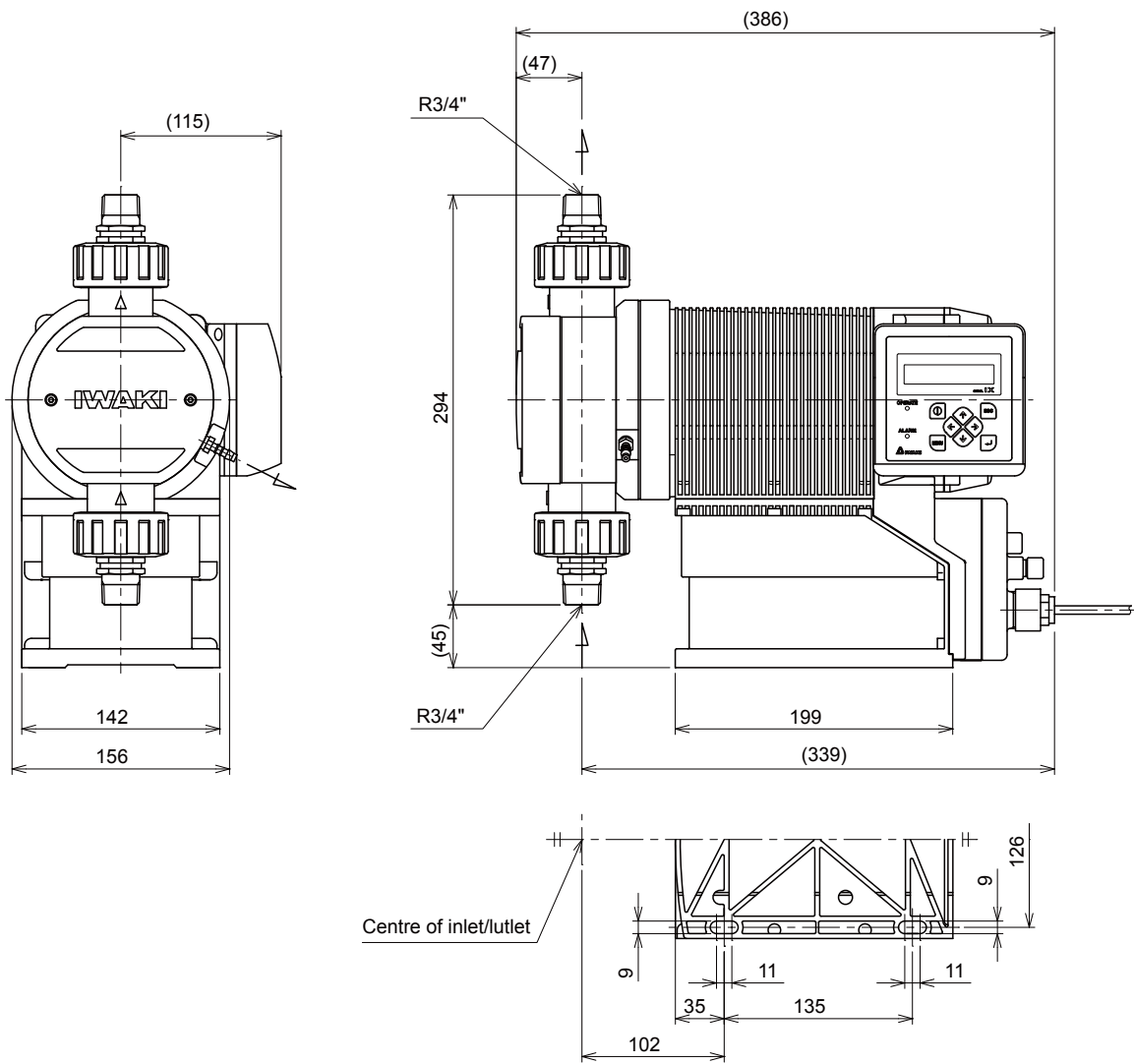

■ IX-C150TCR-LF

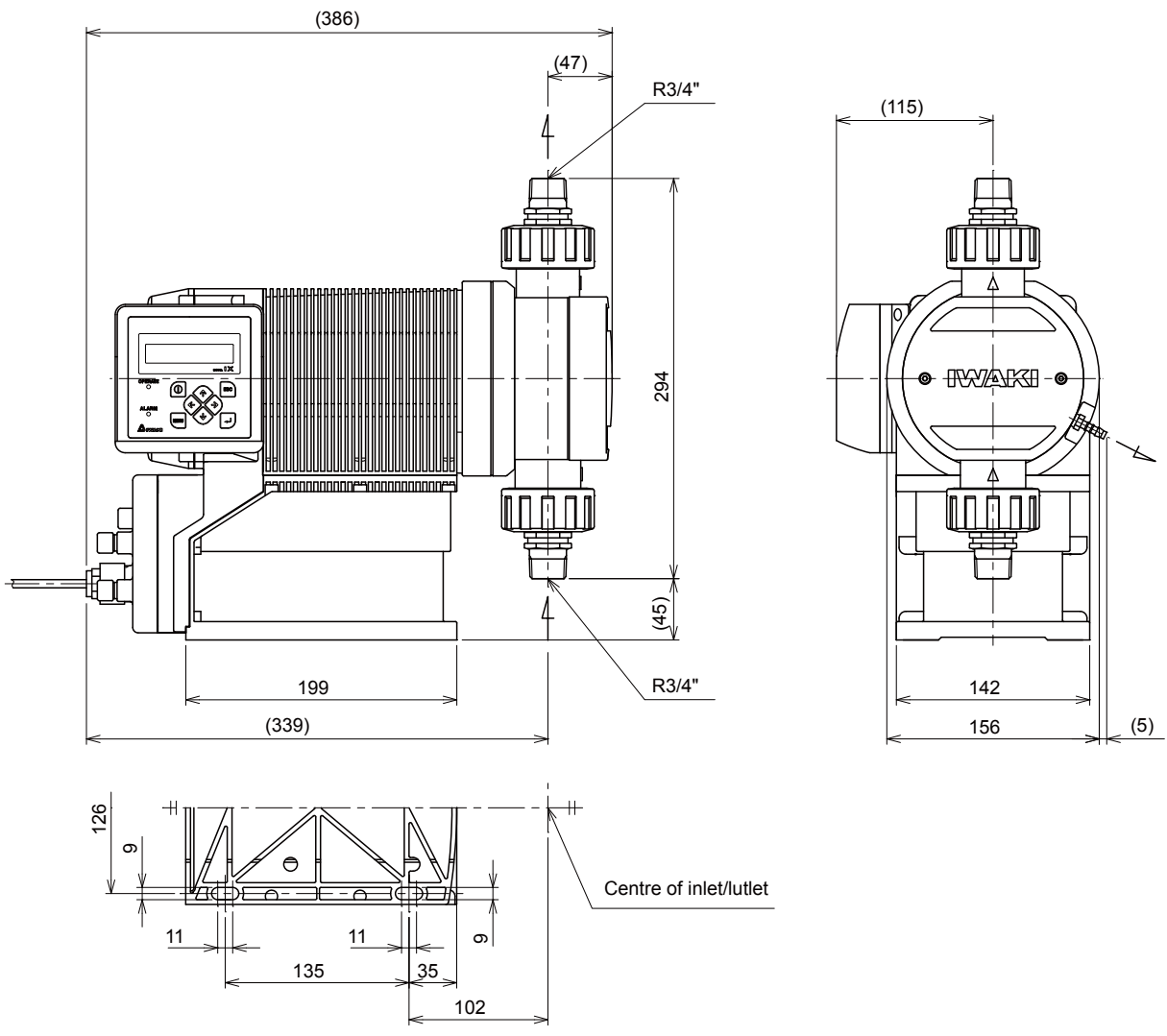

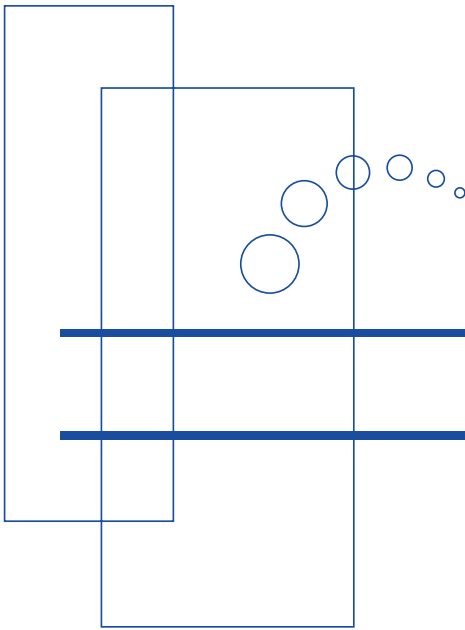

<http://www.iwakipumps.jp>

()Country codes

IWAKI CO.,LTD. 6-6 Kanda-Sudacho 2-chome Chiyoda-ku Tokyo 101-8558 Japan
TEL:(81)3 3254 2935 FAX:3 3252 8892

Australia	IWAKI Pumps Australia Pty. Ltd.	TEL:(61)2 9899 2411	FAX: 2 9899 2421	Italy	IWAKI Italia S.R.L.	TEL:(39)02 990 3931	FAX: 02 990 42888
Austria	IWAKI (Austria) GmbH	TEL:(43)2236 33469	FAX: 2236 33469	Korea	IWAKI Korea Co.,Ltd.	TEL:(82)2 2630 4800	FAX: 2 2630 4801
Belgium	IWAKI Belgium n.v.	TEL:(32)1367 0200	FAX: 1367 2030	Malaysia	IWAKIm Sdn. Bhd.	TEL:(60)3 7803 8807	FAX: 3 7803 4800
China	IWAKI Pumps (Shanghai) Co., Ltd.	TEL:(86)21 6272 7502	FAX: 21 6272 6929	Norway	IWAKI Norge AS	TEL:(47)6681 1660	FAX: 6681 1661
China	IWAKI Pumps (Guandong) Co., Ltd.	TEL:(86)750 3866228	FAX: 750 3866278	Singapore	IWAKI Singapore Pte. Ltd.	TEL:(65)6316 2028	FAX: 6316 3221
China	GFTZ IWAKI Engineering & Trading (Guangzhou)	TEL:(86)20 8435 0603	FAX: 20 8435 9181	Spain	IWAKI Iberica Pumps, S.A.	TEL:(34)943 630030	FAX: 943 628799
China	GFTZ IWAKI Engineering & Trading (Beijing)	TEL:(86)10 6442 7713	FAX: 10 6442 7712	Sweden	IWAKI Sverige AB	TEL:(46)8 511 72900	FAX: 8 511 72922
Denmark	IWAKI Nordic A/S	TEL:(45)48 24 2345	FAX: 48 24 2346	Switzerland	IWAKI (Schweiz) AG	TEL:(41)26 674 9300	FAX: 26 674 9302
Finland	IWAKI Suomi Oy	TEL:(358)9 2745810	FAX: 9 2742715	Taiwan	IWAKI Pumps Taiwan Co., Ltd.	TEL:(886)2 8227 6900	FAX: 2 8227 6818
France	IWAKI France S.A.	TEL:(33)1 69 63 33 70	FAX: 1 64 49 92 73	Taiwan	IWAKI Pumps Taiwan (Hsin-chu) Co., Ltd.	TEL:(886)3 573 5797	FAX:(886)3 573 5798
Germany	IWAKI EUROPE GmbH	TEL:(49)2154 9254 0	FAX: 2154 9254 48	Thailand	IWAKI (Thailand) Co., Ltd.	TEL:(66)2 322 2471	FAX: 2 322 2477
Holland	IWAKI Holland B.V.	TEL:(31)547 293 160	FAX: 547 292 332	U.K.	IWAKI Pumps (UK) LTD.	TEL:(44)1743 231363	FAX: 1743 366507
Hong Kong	IWAKI Pumps Co., Ltd.	TEL:(852)2 607 1168	FAX: 2 607 1000	U.S.A.	IWAKI AMERICA Inc.	TEL:(1)508 429 1440	FAX: 508 429 1386
Indonesia	IWAKI Singapore (Indonesia Branch)	TEL:(62)21 690 6606	FAX: 21 690 6612	Vietnam	IWAKI pumps Vietnam Co.,Ltd.	TEL:(84)613 933456	FAX: 613 933399